

Installation Instructions

For Type R-RH Rotary Unions (2-1/2" – 4")

SAFETY INSTRUCTIONS

Please follow your company's safety procedures whenever working on Johnson-Fluiten rotary unions and read all of the instructions completely before proceeding. Please refer to the engineer drawings of your Johnson-Fluiten rotary union for part identification. If you have any question, please contact your sales representative or Johnson-Fluiten directly.

PRELIMINARY CHECKS

Before proceeding with assembly check:

- **Rotor housing:** diameter and depth of threading
- **Coupling flange** (when applied): number, dimension and bolt circle of coupling holes
- **Geometrical tolerances:** concentricity ($Y=0.3$) and perpendicularity ($AY=0.2$) between housing and rotor. At high RPM's the bearings will yield longer service life if runout is kept to a minimum
- **Rotary joint connections:** verify that fittings are suitable for connections (see dimensions in our catalogue or in customized drawing)

WARNING

Prior to mounting the joint to the roll end, care should be taken to ensure that connections faces are clean and free of burrs. A lifting mechanism such as a crane or hoist may be used to support the weight of the joint during installation.

INSTALLATION INSTRUCTIONS

Single flow (M) – No horizontal pipe

Attach in manner described in *Mounting to Journal* given your rotor design.

Dual flow (F) – stationary horizontal pipe

Dual flow (L) – rotating horizontal pipe

Holding union straight, slide the assembly slowly over the horizontal siphon pipe, allowing the pipe to fit into the body bushing / thread, then attach to journal as described in *Mounting to Journal*.

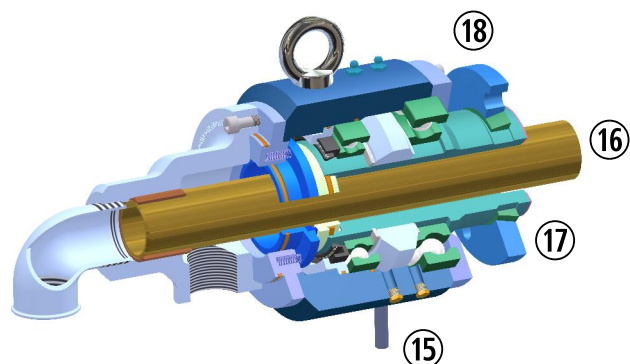

Mounting to journal

Threaded rotor: lubricate connections using recommended fluid mineral oil, thread the rotor into journal and tighten straight the gasket

Quick release rotor: place gasket (16) in journal flange recess. Slide the quick release flange (18) over the rotor with the taper facing away from the union. Place splitwedges (17) into the rotor recess, then slide the quick release flange over it. Position union/flange into journal flange and tighten the fasteners evenly.

There will be a 3-5mm gap between the journal flange and the quick release flange.

- **Integral flanged rotor:** place gasket on rotor flange by fitting it over the pilot, then slip the pilot of nipple flange into the counterbore in the roll end. Attach with appropriate fasteners for the application. Tighten nuts evenly in a star pattern to the proper torque, in order to seal flange surfaces and minimize runout.

INSTALLATION NOTES

- **NOTICE** Take special care when mounting union over siphon pipe as internal seals can be damaged
- Siphon pipe can be guided to the body bushing/thread while looking through the M connection
- Pay attention on length of siphon pipe. excess length can cause flow to be cut off against interior of elbow
- **WARNING** Avoid locking of fittings with the rotary joint installed on journal. Locking forces could get deformed rotor or damage bearings

WARNING Apply soft pads on clamping device. Avoid excessive clamping which could damage bearing support.

FLEXIBLE HOSE CONNECTIONS

Given your application, choose either rubber or metal braided hose, with ratings able to sustain the flow media. When connecting the rotary union to the fixed piping, the flexible hose

should be installed as close to the union as possible, in a relaxed condition, neither stretched or compressed.

If you have unusual long run of hose, it is strongly suggested you to support the hose so as not to overload the bearings. Refer to Table 2 to determine the correct length of flexible hose needed to isolate the rotary union from piping stresses and to Table 3 for correct examples of installation.

WEEP HOLES

The weep holes in the body of rotary union provide escape of leakage at the internal seals which indicate the need for seal replacement.

NOTICE The rotary union should be oriented such that one of the weep holes is pointing directly downward. See Table 1 for detail of number and size of holes.

ANTI-ROTATION DEVICE

R/RH joints are furnished with one anti-rotation device (15), which serves the purpose of holding the joint body stationary while the roll is turning.

WARNING Without an anti-rotation device the torque applied by the rotation of the joint would pull and strain the flexible hose connecting the joint to the piping. This load could cause premature hose failure.

FUNCTIONAL TEST

It is not possible to define in detail the functional test which will depend on the type of installation., some general suggestions are specified below:

Start the machinery and operate for 5 minutes verifying:

- Absence of leakage
- Absence of vibration or abnormal noises produced by rotary joint
- Absence of excessive heating of rotary joint, in particular in the area of ball bearing

Table 1

Size	description	Dimension	Key	Torque (N*m)
R064	Rotor	2-1/2" G-ISO228		
	Body-support screw	M8	6	8.5
	Screw for Q flange	M12	13	26.5
	Weep holes	5 x 1/8"		
R076	Rotor	3" G-ISO228		
	Body-support screw	M10	8	17.5
	Screw for Q flange	M16	24	71.5
	Weep holes	5 x 1/8"		
R089	Rotor	3-1/2" G-ISO228		
	Body-support screw	M10	8	17.5
	Screw for Q flange	M16	24	71.5
	Weep holes	5 x 1/8"		
R102	Rotor	4" G-ISO228	36	
	Body-support screw	M10	8	17.5
	Screw for Q flange	M16	24	71.5
	Weep holes	5 x 1/8"		
R125	Rotor	5" K/F		
	Body-support screw	M12	13	26.5
	Screw for Q flange	M12	13	26.5
	Weep holes	5 X 1/4"		
R150	Rotor	6" K/F		
	Body-support screw	M16	24	71.5
	Screw for Q flange	M12	13	26.5
	Weep holes	5 x 1/4"		

Table 3

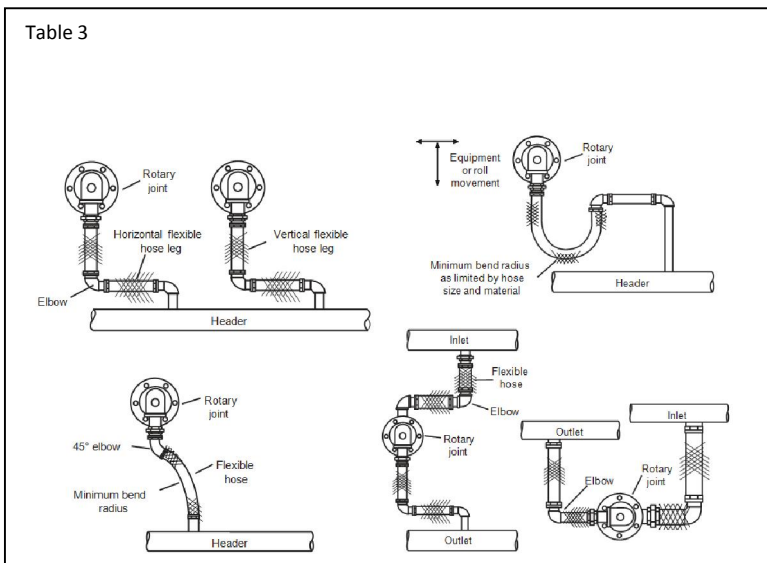

Table 2

RECOMMENDED MINIMUM HOSE LENGHT	
2-1/2"	560 mm
3"	610 mm
3-1/2"	660 mm
4"	710 mm
5"	760 mm

	Type	R	RH	R	RH	R	RH	R	RH	R	RH	R	RH
	Size	064		076		089		102		125		150	
Air	Pressure bar	10		5		5		4		4		3	
	Speed rpm	375		375		350		300		250		200	
Water up to 120°C	Pressure bar	25		25		20		20		20		15	
	Speed rpm	750		750		700		600		500		400	
Water / Oil up to 180°C	Pressure bar	-	12,5		12,5		12,5		10		10		7,5
	Speed rpm	-	750		750		700		600		500		400
Steam up to 180°C	Pressure bar	-	12,5		12,5		12,5		10		10		7,5
	Speed rpm	-	375		750		700		600		500		400

Johnson-Fluiten Warranty

Johnson-Fluiten products are built to a high standard of quality. Performance is what you desire: that is what we provide. Johnson-Fluiten products are warranted against defects in materials and workmanship for a period of one year after date of shipment. It is expressly understood and agreed that the limit of Johnson-Fluiten's liability shall, at Johnson-Fluiten's sole option, be the repair or resupply of a like quantity of non-defective product.

