

Disassembly and Repair Instructions For Type R-RH Rotary Unions (2-1/2" – 6")

SAFETY INSTRUCTIONS

Please follow your company's safety procedures whenever working on Johnson-Fluiten rotary unions and read all of the instructions completely before proceeding. Please refer to the engineer drawings of your Johnson-Fluiten rotary union for part identification. If you have any question, please contact your sales representative or Johnson-Fluiten directly.

Lubricate all fasteners with anti-seize compound. Tighten all fasteners in a star pattern. Torque specifications are listed in **Installation Instructions** or at www.johnson-fluiten.com

Release residual pressure in the system. Close the inlet and outlet valve and allow the union to cool sufficiently.

ORDINARY MAINTENANCE

Ball bearing lubrication

For ballbearing lubrication use lubricator (48). Pump grease till clean grease is coming out from the lip seal on connection side.

Rotary joint type R requires regreasing with SKF LGMT3/5 or equivalent every 500 hours

Rotary joint type RH needs to be lubricated with Krytox GPL226 or equivalent every 5000 hours for operating temperature up to 150°C, every 2000 hours for temperature over 150°C.

See Table 1 for detail of quantity of needed grease.

Table1: quantity of Krytox grease for bearings (RH joints)

SIZE	Q.ty (c.c.)
RH064	50
RH076	80
RH089	95



Sealings replacement

- Loosen and remove screws (11), disengage body (33) from flange (50).
- Loosen and remove screws (12)
- Remove from flange (50) the stationary sealring (1) with oring (10) and set of springs (13).
- Remove from rotor (02) sealring (2A) with oring (9)
- Insert new sealring and gasket into rotor.
- Insert new springs (13) in relevant holes in flange (50)
- Insert new sealring (01) with gasket (10) in flange (50) housing

NOTICE

Use lubricant Silicon grease SIL133 or equivalent

- Reassembly flange (59) and lock screws (12)
- Reassembly body (33) and and lock screws (11)

ADVANCED MAINTENANCE

Replacement of ball bearings

NOTICE

Replacement with new prelubricated Johnson-Fluiten bearings is recommended.

- Remove screws (04) and flange (03)
- Remove rotor (02) with ballbearing (21)
- Remove elastic ring (41) and bearing (22)
- Remove bearing (21)
- Assembly new bearing (22) and elastic ring (41)

- Assembly new bearing (21) on rotor (02) and fit in place elastic ring (42)
- Reassembly rotor (02) complete of bearing (21)
- Reassembly flange (3) and lock screws (11)

NOTICE See torque values on Table 1 from installation instruction ISR_RH102_EN

NOTICE Refer to installation instruction ISR_RH102_EN for any information and advice related to installation of the joint

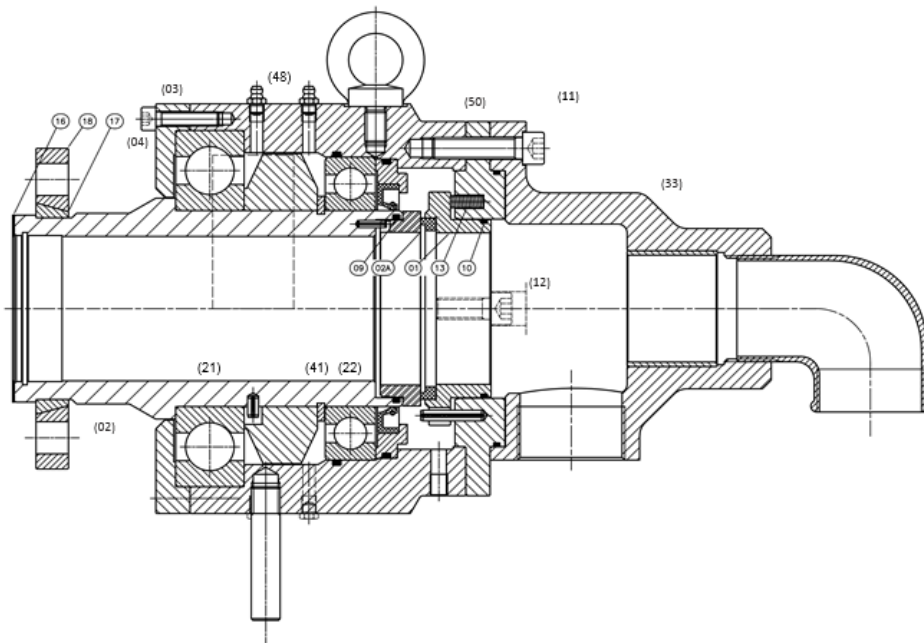

TROUBLESHOOTING		
PROBLEM	PROBABLE CAUSE	ACTION
Leakage detected at drain holes	Wear or damage of sealings	Replacement of sealing elements (repair kit)
	Damage of gaskets (09) (10)	
Overheating or elevated noise	Insufficient lubrication of ballbearings	Lubrication as described
	Wear of ballbearings	Replacement of ballbearings (bearing kit)

Johnson-Fluiten Warranty

Johnson-Fluiten products are built to a high standard of quality. Performance is what you desire: that is what we provide. Johnson-Fluiten products are warranted against defects in materials and workmanship for a period of one year after date of shipment. It is expressly understood and agreed that the limit of Johnson-Fluiten's liability shall, at Johnson-Fluiten's sole option, be the repair or resupply of a like quantity of non-defective product.

