

# RX<sup>®</sup> Rotary Unions

For water, air, and thermal oil service

Engineered reliability for demanding applications.



*Advanced rotary unions  
for fluid and air service*



# RX Rotary Union

- Overview 3/8" to 1 1/2" RX..... 3
- 3/8" to 1 1/2" RX..... 4
- 3/8" to 1 1/2" RX-1..... 6
- Seal Replacement..... 8
- Overview 2" to 3" RX..... 9
- 2" to 3" RX..... 10
- 2" to 3" RX-1..... 12
- 2" to 3" RX-3..... 14
- 4" RX, RX-1, RX-2, RX-3..... 16
- 5" to 6" RX-1, RX-2, RX-3..... 18
- Engineering Data..... 19
- Custom Solutions..... 20
- Cartridge Options..... 21
- Quick Release Flange..... 22
- Complementary Products..... 24
- Other Rotary Joints..... 25
- Recommendations..... 26

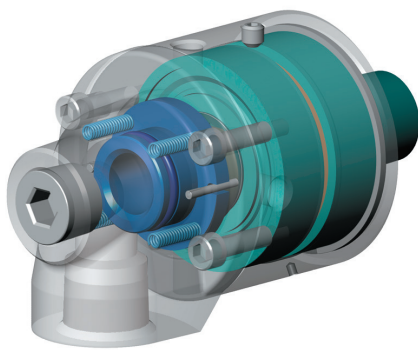

Single flow rotary union

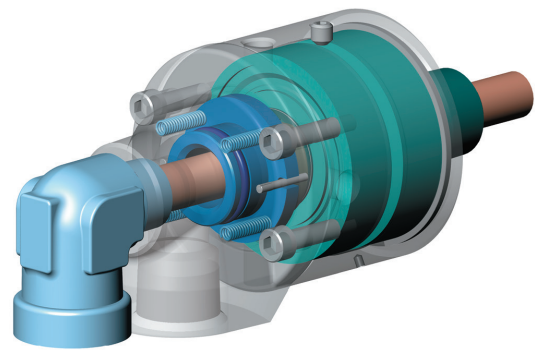

Dual flow rotary union

## Quick Select Chart

Size	Model	Media				Pressure (Max.)	Temperature (Max.)	Speed (RPM)
		Water	Thermal Oil	Steam	Air	BAR	°C	
3/8" to 1 1/2"	RX	●	●	●	●	13	105	3.500
	RX-1	●	●	●	●	13	180	3.500
	RX-2	●	●	●	●	13	205	3.500
	RX-3	●	●	●	●	13	230	3.500
2" to 3"	RX	●	●	●	●	13	105	1.000
	RX-1	●	●	●	●	13	180	1.000
	RX-2	●	●	●	●	13	205	1.000
	RX-3	●	●	●	●	13	250	1.000
4" to 6"	RX	●	●	●	●	10	150	750
	RX-1	●	●	●	●	10	160	750
	RX-2	●	●	●	●	10	205	750
	RX-3	●	●	●	●	10	250	750

- Recommended
- Acceptable
- Not Recommended

*Do not operate unions at maximum values of pressure, temperature, and speed.*

*See page 27 for maximum speed per nipple type.*

# Overview 3/8" to 1 1/2" RX

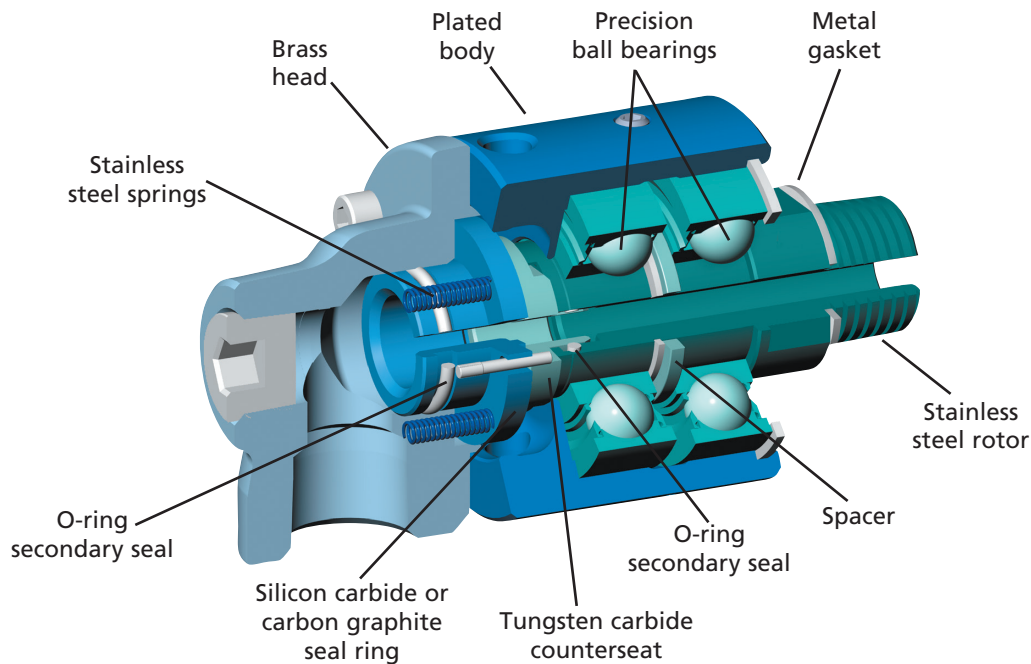

The RX rotary union connects stationary piping to a rotating device. The fluid is sealed by precision, micro-lapped seals that provide a uniform, full-flow design. The union is supported by two widely-spaced anti-friction bearings and is available with a bearing isolation system for added bearing protection. The RX union is capable of intermittent dry running and features a 100% pure-molded carbon graphite or silicon carbide seal and tungsten carbide counterseat.

Kadant Johnson can provide seal materials specific for food and pharmaceutical industries regulated by the FDA/EFSA. Those materials comply with high Kadant Johnson standards. Seal life may vary from the standard seal materials based on the specific application. For food service, Kadant Johnson uses Green Streak™ seal rings. These seals can last up to three times longer than resin seals.

The RX rotary joint is available for use in a potentially explosive atmosphere defined by ATEX.

The RX rotary joint is manufactured according to Pressure Equipment Directive (PED 97/23/EC).



## Features

- Springs located outside the flow area
- Stainless steel rotor
- Two-piece housing, on-machine seal replacement
- O-rings fully captured in glands
- Balanced seal assembly
- Full flow area
- Matched seal faces
- Bearing isolation system available
- Tungsten carbide counterseat



## Benefits

- Improved reliability, increased flow area
- Corrosion resistant
- Reduced down-time and cost of maintenance
- Robust design, no risk of o-ring slipping
- Extended operating life
- Low pressure drop
- Materials selected for specific service
- Increased bearing protection
- Added toughness and shock resistance

# 3/8" to 1 1/2"

## Single and Dual Flow



### Standard RX\* Ratings

Media:	Water/Air	Oil
Pressure:	13 bar	10 bar
Temperature:	105°C	105°C
Speed:	3.500 RPM	3.500 RPM

\*Consult Kadant Johnson for RX-2 and RX-3 unions for applications up to 230°C and for abrasive fluids.

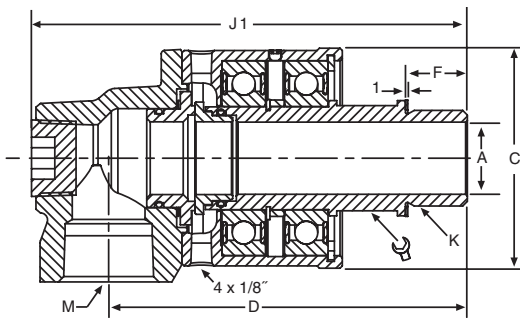

Single flow straight thread rotor

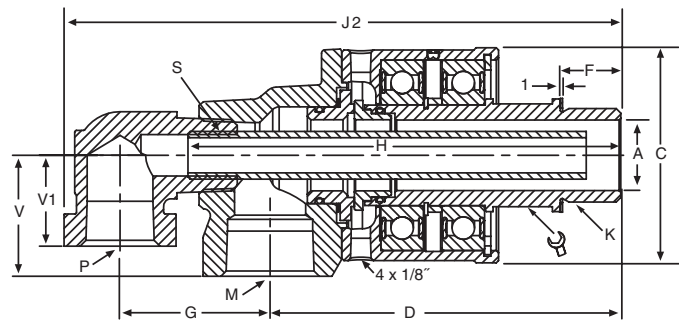

Dual flow straight thread rotor

Media: Water, air, and steam\*\*

Model	K ISO-228-1 Rotor	M* ISO-228-1 RH	Part ID – Water/Steam/Air**			A	C	D	F	G	H		J1	J2	P* ISO-228-1 RH	S		V	V1	Approx. Weight		
			Single Flow	Dual Flow Fixed Pipe	Dual Flow Rotary Pipe						Fixed Pipe	Rotary Pipe				Fixed Pipe ISO-228-1	Rotary Pipe OD f7					
4038	G 3/8" -RH	G 3/8"	995.135/0002	995.595/0006	–	9,5	64	100	16	36	117	117	119	150	G 1/4"	M6 x 1"	–	35	30	24	0,9 Kg	
	G 3/8" -LH		995.135/0003	995.595/0007	–																	
4050	G 1/2" -RH	G 1/2"	995.530/0007	995.531/0009	995.532/0007	12,7	64	103	19	36	125	123	122	153	G 3/8"	G 1/8" -RH	10	35	30	24	1,4 Kg	
	G 1/2" -LH		995.530/0008	995.531/0010	995.532/0008																	
4075	G 3/4" -RH	G 3/4"	995.533/0006	995.534/0008	995.535/0006	17,3	73	113	19	43	140	143	138	173	G 1/2"	G 1/4" -RH	13	40	36	32	2,3 Kg	
	G 3/4" -LH		995.533/0008	995.534/0009	995.535/0007																	
4100	G 1" -RH	G 1"	995.536/0007	995.537/0013	995.538/0010	23,0	91	131	22	55	161	164	159	206	G 1/2"	G 3/8" -RH	16	48	41	40	3,6 Kg	
	G 1" -LH		995.536/0008	995.537/0014	995.538/0011																	
	Q Flange		995.536/	995.537/	995.538/	23,0	91	148	55	55	161	164	176	224	G 1/2"	G 3/8" -RH	16	48	41	40	3,6 Kg	
4125	G 1 1/4" -RH	G 1 1/4"	995.539/0006	995.540/0007	995.541/0007	31,5	96	157	27	67	193	205	190	249	G 3/4"	G 1/2" -RH	22	54	40	46	4,5 Kg	
	G 1 1/4" -LH		995.539/0007	995.540/0011	995.541/0008																	
	Q Flange		995.539/	995.540/	995.541/	31,5	96	157	63	67	193	205	198	257	G 3/4"	G 1/2" -RH	22	54	40	46	4,5 Kg	
4150	G 1 1/2" -RH	G 1 1/2"	995.542/0009	995.543/0008	995.544/0007	38,1	116	182	28	69	225	230	220	275	G 3/4"	G 3/4" -RH	26	60	52	54	7,2 Kg	
	G 1 1/2" -LH		995.542/0010	995.543/0010	995.544/0008																	
	Q Flange		995.542/0011	995.543/0014	995.544/0016	38,1	116	182	69	69	230	235	225	281	G 3/4"	G 3/4" -RH	26	60	52	54	7,2 Kg	

\* For additional connection sizes/reducers, consult Kadant Johnson.

\*\* Steam is not recommended.

Dimensions are in mm, are for reference only, and subject to change.

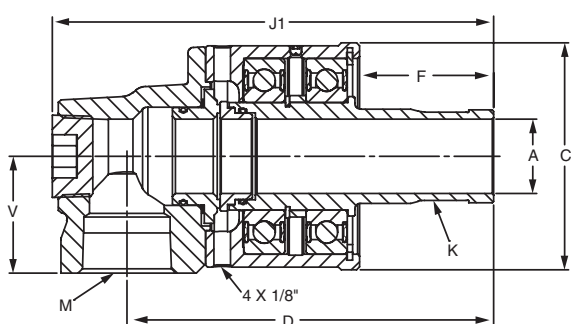
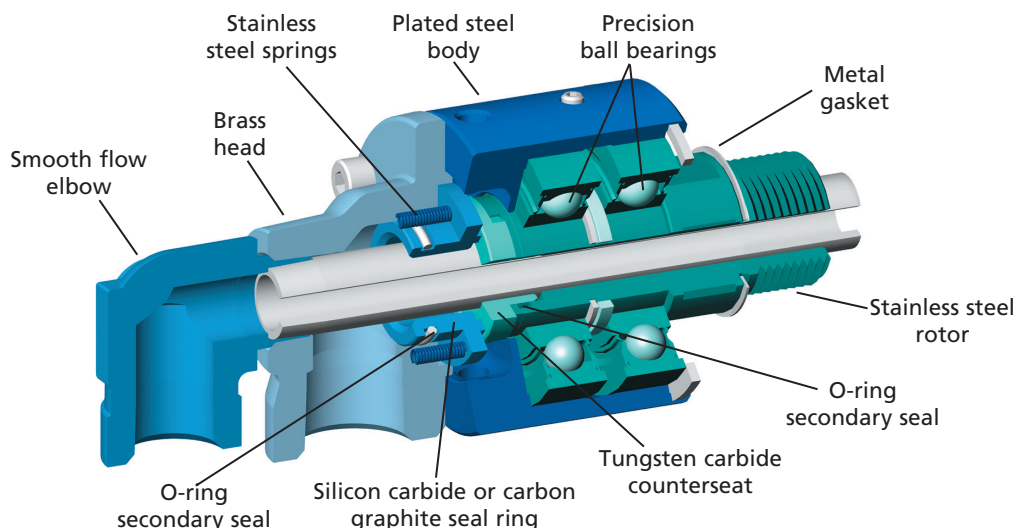

Single flow with Q-flange rotor

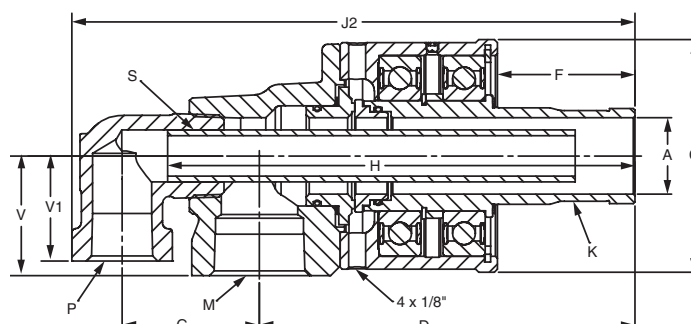

Dual flow with Q-flange rotor

Media: Oil

Model	K ISO-228-1 Rotor	M* ISO-228-1 RH	Part ID – Oil			A	C	D	F	G	H		J1	J2	P* ISO-228-1 RH	S		V	V1	Approx. Weight	
			Single Flow	Dual Flow Fixed Pipe	Dual Flow Rotary Pipe						Fixed Pipe	Rotary Pipe				Fixed Pipe ISO-228-1	Rotary Pipe OD f7				
4038	G 3/8" -RH	G 3/8"	995.178/0001	995.137/0001	–	9,5	64	100	16	36	117	117	119	150	G 1/4"	M6 x 1"	–	35	30	24	0,9 Kg
	G 3/8" -LH		995.178/0002	995.137/0002	–																
4050	G 1/2" -RH	G 1/2"	995.138/0001	995.139/0001	995.140/0001	12,7	64	103	19	36	125	123	122	153	G 3/8"	G 1/8" -RH	10	35	30	24	1,4 Kg
	G 1/2" -LH		995.138/0002	995.139/0002	995.140/0002																
4075	G 3/4" -RH	G 3/4"	995.141/0001	995.142/0001	995.143/0001	17,3	73	113	19	43	140	143	138	173	G 1/2"	G 1/4" -RH	13	40	36	32	2,3 Kg
	G 3/4" -LH		995.141/0002	995.142/0002	995.143/0002																
4100	G 1" -RH	G 1"	995.144/0001	995.145/0001	995.146/0001	23,0	91	131	22	55	161	164	159	206	G 1/2"	G 3/8" -RH	16	48	41	40	3,6 Kg
	G 1" -LH		995.144/0002	995.145/0002	995.146/0002																
	Q Flange		995.144/	995.145/	995.146/																
4125	G 1 1/4" -RH	G 1 1/4"	995.147/0001	995.148/0001	995.149/0001	31,5	96	157	27	67	193	205	190	249	G 3/4"	G 1/2" -RH	22	54	40	46	4,5 Kg
	G 1 1/4" -LH		995.147/0002	995.148/0002	995.149/0002																
	Q Flange		995.147/	995.148/	995.149/																
4150	G 1 1/2" -RH	G 1 1/2"	995.150/0001	995.151/0001	995.152/0001	38,1	116	182	28	69	225	230	220	275	G 3/4"	G 3/4" -RH	26	60	52	54	7,2 Kg
	G 1 1/2" -LH		995.150/0002	995.151/0002	995.152/0002																
	Q Flange		995.150/	995.151/	995.152/																

\* For additional connection sizes/reducers, consult Kadant Johnson.

Dimensions are in mm, are for reference only, and subject to change.

# 3/8" to 1 1/2"

## Single and Dual Flow



### Standard RX-1\* Ratings

Media:	Water/Air	Oil
Pressure:	13 bar	10 bar
Temperature:	180°C	180°C
Speed:	3.500 RPM	3.500 RPM

\*Consult Kadant Johnson for RX-2 and RX-3 unions for applications up to 230°C and for abrasive fluids.

Consult Kadant Johnson for the correct greasing intervals.

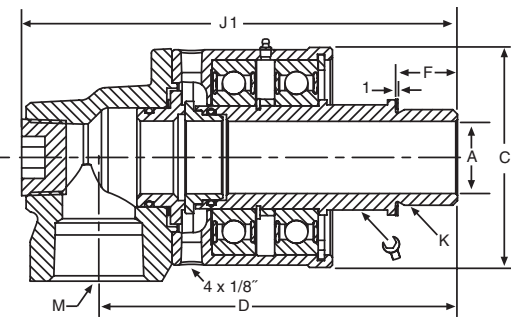

Single flow straight thread rotor

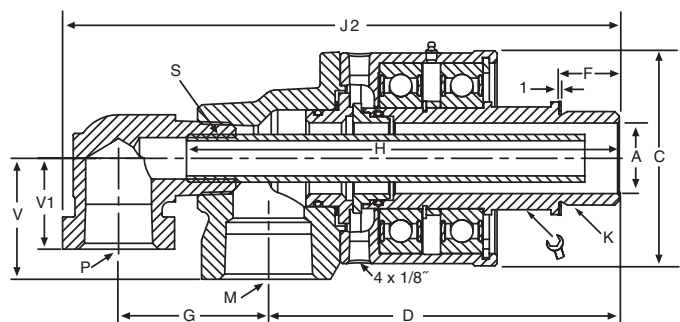

Dual flow straight thread rotor

Media: Water, air, and steam\*\*

Model	K ISO-228-1 Rotor	M* ISO-228-1 RH	Part ID – Water/Steam/Air			A	C	D	F	G	H		J1	J2	P* ISO-228-1 RH	S		V	V1	Approx. Weight	
			Single Flow	Dual Flow Fixed Pipe	Dual Flow Rotary Pipe						Fixed Pipe	Rotary Pipe				Fixed Pipe ISO-228-1	Rotary Pipe OD f7				
4038	G 3/8" -RH	G 3/8"	995.158/0001	995.159/0001	–	9,5	64	100	16	36	117	117	119	150	G 1/4"	M6 x 1"	–	35	30	24	0,9 Kg
	G 3/8" -LH		995.158/0002	995.159/0002	–																
4050	G 1/2" -RH	G 1/2"	995.122/0002	995.123/0002	995.124/0002	12,7	64	103	19	36	125	123	122	153	G 3/8"	G 1/8" -RH	10	35	30	24	1,4 Kg
	G 1/2" -LH		995.122/0003	995.123/0003	995.124/0003																
4075	G 3/4" -RH	G 3/4"	995.125/0005	995.126/0002	995.127/0002	17,3	73	113	19	43	140	143	138	173	G 1/2"	G 1/4" -RH	13	40	36	32	2,3 Kg
	G 3/4" -LH		995.125/0006	995.126/0003	995.127/0003																
4100	G 1" -RH	G 1"	995.546/0003	995.128/0002	995.129/0003	23,0	91	131	22	55	161	164	159	206	G 1/2"	G 3/8" -RH	16	48	41	40	3,6 Kg
	G 1" -LH		995.546/0004	995.128/0003	995.129/0004																
	Q Flange		995.546/	995.128/	995.129/																
4125	G 1 1/4" -RH	G 1 1/4"	995.130/0003	995.131/0002	995.545/0006	31,5	96	157	27	67	193	205	190	249	G 3/4"	G 1/2" -RH	22	54	40	46	4,5 Kg
	G 1 1/4" -LH		995.130/0004	995.131/0003	995.545/0007																
	Q Flange		995.130/	995.131/	995.545/																
4150	G 1 1/2" -RH	G 1 1/2"	995.132/0004	995.133/0003	995.134/0002	38,1	116	182	28	69	225	230	220	275	G 3/4"	G 3/4" -RH	26	60	52	54	7,2 Kg
	G 1 1/2" -LH		995.132/0005	995.133/0004	995.134/0003																
	Q Flange		995.132/	995.133/0006	995.134/																

\* For additional connection sizes/reducers, consult Kadant Johnson.

\*\* Steam is not recommended.

Dimensions are in mm, are for reference only, and subject to change.

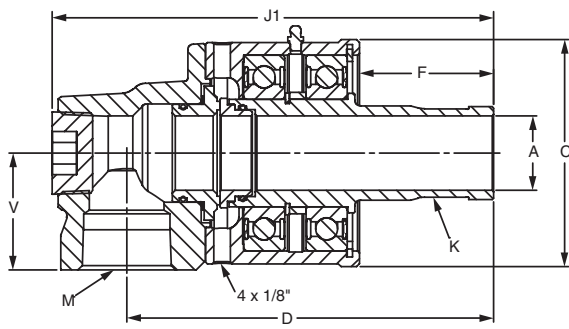
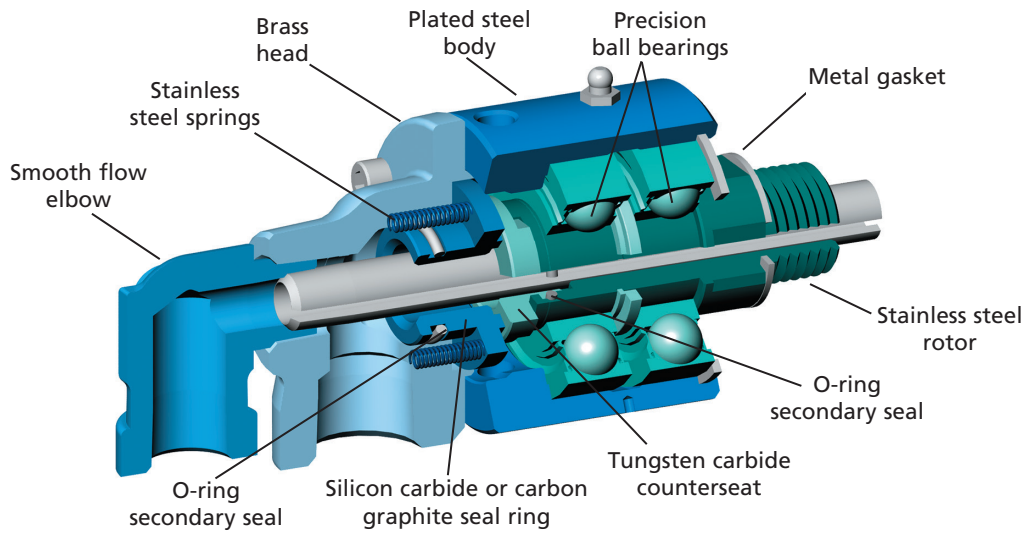

Single flow with Q-flange rotor

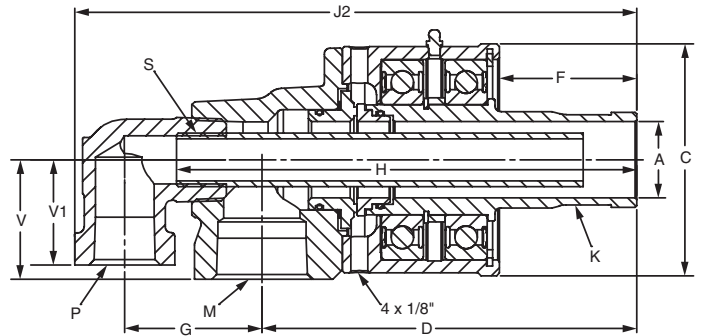

Dual flow with Q-flange rotor

Media: Oil

Model	K ISO-228-1 Rotor	M* ISO-228-1 RH	Part ID – Oil			A	C	D	F	G	H		J1	J2	P* ISO-228-1 RH	S		V	V1	Approx. Weight		
			Single Flow	Dual Flow Fixed Pipe	Dual Flow Rotary Pipe						Fixed Pipe	Rotary Pipe				Fixed Pipe ISO-228-1	Rotary Pipe OD f7					
4038	G 3/8" -RH	G 3/8"	995.161/0001	995.162/0001	–	9,5	64	100	16	36	117	117	119	150	G 1/4"	M6 x 1	–	35	30	24	0,9 Kg	
	G 3/8" -LH		995.161/0002	995.162/0002	–																	
4050	G 1/2" -RH	G 1/2"	995.163/0001	995.164/0001	995.165/0001	12,7	64	103	19	36	125	123	122	153	G 3/8"	G 1/8" -RH	10	35	30	24	1,4 Kg	
	G 1/2" -LH		995.163/0002	995.164/0002	995.165/0002																	
4075	G 3/4" -RH	G 3/4"	995.166/0001	995.167/0001	995.168/0001	17,3	73	113	19	43	140	143	138	173	G 1/2"	G 1/4" -RH	13	40	36	32	2,3 Kg	
	G 3/4" -LH		995.166/0002	995.167/0002	995.168/0002																	
4100	G 1" -RH	G 1"	995.169/0001	995.170/0001	995.171/0001	23,0	91	131	22	55	161	164	159	206	G 1/2"	G 3/8" -RH	16	48	41	40	3,6 Kg	
	G 1" -LH		995.169/0002	995.170/0002	995.171/0002																	
	Q Flange		995.169/	995.170/	995.171/	23,0	91	148	55	55	161	164	176	224	G 1/2"	G 3/8" -RH	16	48	41	40	3,6 Kg	
4125	G 1 1/4" -RH	G 1 1/4"	995.172/0001	995.173/0001	995.174/0001	31,5	96	157	27	67	193	205	190	249	G 3/4"	G 1/2" -RH	22	54	40	46	4,5 Kg	
	G 1 1/4" -LH		995.172/0002	995.173/0002	995.174/0002																	
	Q Flange		995.172/	995.173/	995.174/	31,5	96	157	63	67	193	205	198	257	G 3/4"	G 1/2" -RH	22	54	40	46	4,5 Kg	
4150	G 1 1/2" -RH	G 1 1/2"	995.175/0001	995.176/0001	995.177/0001	38,1	116	182	28	69	225	230	220	275	G 3/4"	G 3/4" -RH	26	60	52	54	7,2 Kg	
	G 1 1/2" -LH		995.175/0002	995.176/0002	995.177/0002																	
	Q Flange		995.175/	995.176/	995.177/	38,1	116	182	69	69	230	235	225	281	G 3/4"	G 3/4" -RH	26	60	52	54	7,2 Kg	

\* For additional connection sizes/reducers, consult Kadant Johnson.

Dimensions are in mm, are for reference only, and subject to change.

# Seal Replacement

## Easy seal replacement

The RX line has a unique feature. The complete line from 3/8" to 6" is featured with a Quick Replacement Design (QRD). This feature will allow you to repair the RX union while the union is still installed on the machine. The Kadant RX union is the only one offering this feature in a ball bearing line. The RX union is designed for long operating life and short maintenance time to guarantee the best operating times for your production line.

## How does it work?

Step 1.

Loosen and remove socket head cap screws (2A) and set aside. Remove head (2).

Step 2.

Remove seal ring (5), o-ring (12), and springs (7) from head (2) and discard.

Step 3.

Remove counterseat insert (6) and o-ring (12) from nipple (4) and discard.

Step 4.

Carefully clean the o-ring end of the nipple (4) and the bore of the head (2) where the seal ring (5) sits. Do not scratch surfaces. This may be done using a Scotch Brite pad.

Step 5.

Apply a small amount of o-ring lube to both sides of a new o-ring (12) and fit it over the end of the new seal ring (5) into the o-ring groove. Insert new springs (7) into the spring holes in the head (2).

Step 6.

Place a clean soft cloth over the sealing face of the seal ring (5). Align the notches in the seal ring with the pins (13) in the head (2) and gently press the seal ring in to the bore of the head.

Step 7.

Apply a small amount of o-ring lube to both side of a new o-ring (12) for the counterseat (6) and fit it into the o-ring groove in the end of the nipple (4). Align the flats on the OD of the new counterseat (6) with raised ends of the nipple. Gently press the counterseat into the nipple.

Step 8.

Ensure that the seal faces are clean. Clean the faces of the counterseat (6) and seal ring (5) using a lint free cloth and acetone.

Step 9.

Carefully place the head (2) containing the seal ring (5) back onto the body (1). Secure head to body using socket head cap screws (2A). Seal package replacement is complete.

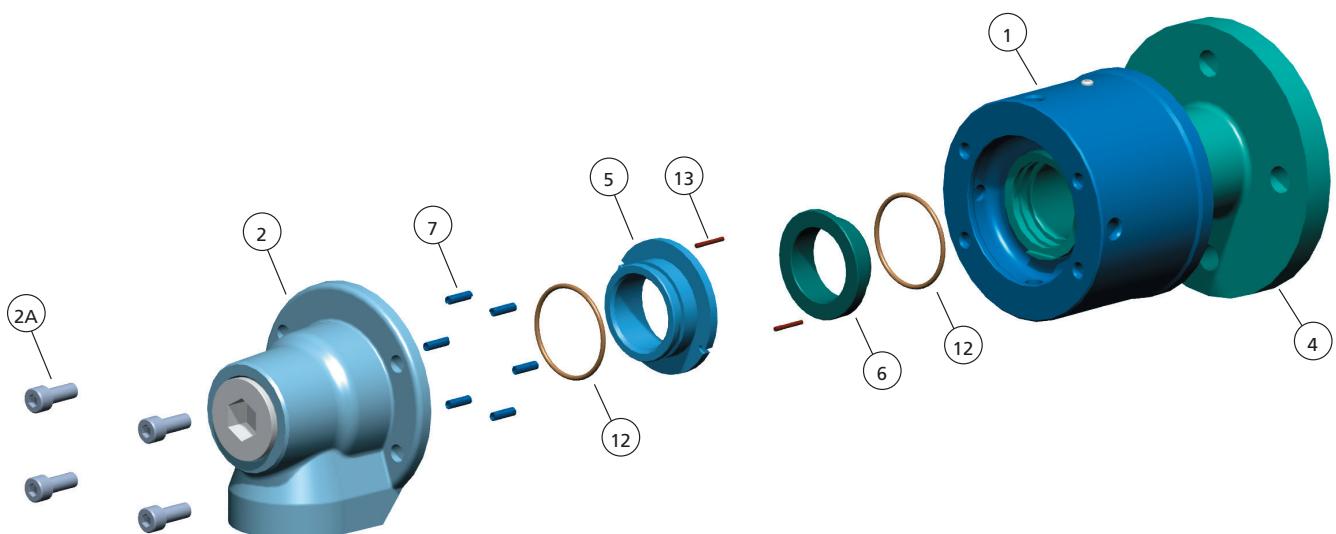



# Overview 2" to 3" RX

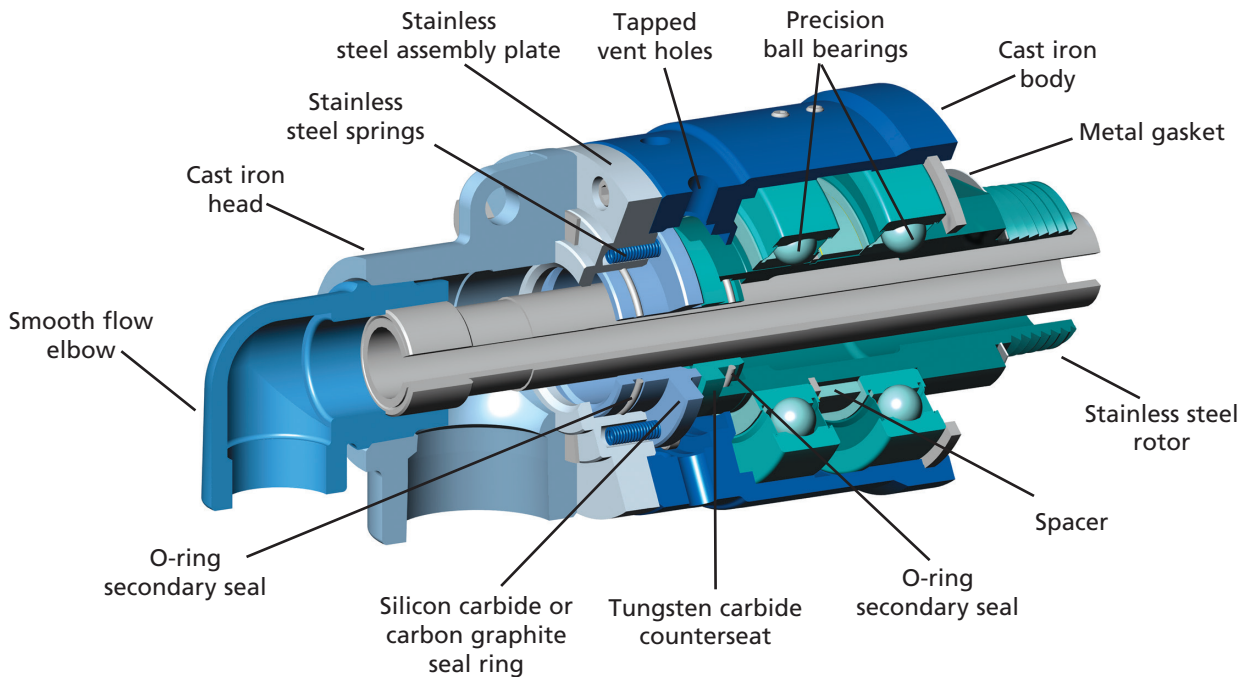

The RX rotary union connects stationary piping to a rotating device. The fluid is sealed by precision, micro-lapped seals that provide a uniform, full-flow design. The union is supported by two widely-spaced anti-friction bearings and is available with a bearing isolation system for added bearing protection. The RX union is capable of intermittent dry running and features a 100% pure-molded carbon graphite or silicon carbide seal and tungsten carbide counterseat.

Kadant Johnson can provide seal materials specific for food and pharmaceutical industries regulated by the FDA/EFSA. Those materials comply with high Kadant Johnson standards. Seal life may vary from the standard seal materials based on the specific application. For food service, Kadant Johnson uses Green Streak™ seal rings. These seals can last up to three times longer than resin seals.

The RX rotary joint is available for use in a potentially explosive atmosphere defined by ATEX.

The RX rotary joint is manufactured according to Pressure Equipment Directive (PED 97/23/EC).



## Features

- Springs located outside the flow area
- Stainless steel rotor
- Two-piece housing, on-machine seal replacement
- O-rings fully captured in glands
- Balanced seal assembly
- Full flow area
- Matched seal faces
- Bearing isolation system available
- Tungsten carbide counterseat
- Spacer between the ball bearings



## Benefits

- Improved reliability, increased flow area
- Corrosion resistant
- Reduced down-time and cost of maintenance
- Robust design, no risk of o-ring slipping
- Extended operating life
- Low pressure drop
- Materials selected for specific service
- Increased bearing protection
- Added toughness and shock resistance
- Improved stability for the union

# 2" to 3"

Single Flow



### Standard RX\* Ratings

Media:	Water	Oil
Pressure:	13 bar	10 bar
Temperature:	105°C	105°C
Speed:	1.000 RPM	1.000 RPM

\*Consult Kadant Johnson for abrasive fluids.

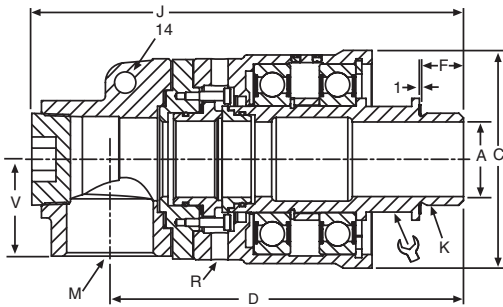

Straight thread rotor

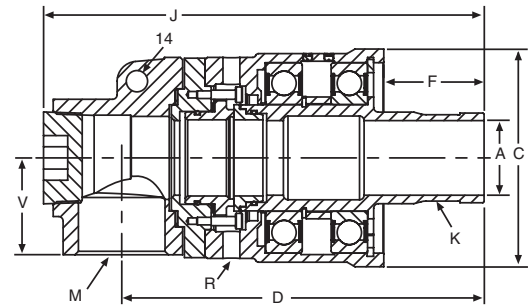

Q flange rotor

Model	K ISO-228-1 Rotor	M** RH	Part ID Water*	A	C	D	F	J	R NPT 8 x RH	V		Approx. Weight
4200	G2"-RH	G2"	995.550/0001	49	143	232	29	284	1/4"	64	70	13 Kg
	G2"-LH	G2"	995.550/0002	49	143	232	29	284	1/4"	64	70	13 Kg
	Q Flange	G2"	995.550/0003	49	143	232	66	289	1/4"	64	-	13 Kg
4250	G2 1/2"-RH	G2 1/2"	995.556/0001	61	174	271	38	334	1/4"	74	83	20 Kg
	G2 1/2"-LH	G2 1/2"	995.556/0002	61	174	271	38	334	1/4"	74	83	20 Kg
	Q Flange	G2 1/2"	995.556/0003	61	174	271	72	334	1/4"	74	-	20 Kg
4300	G3"-RH	G3"	995.562/0001	74	200	328	45	398	3/8"	87	95	29 Kg
	G3"-LH	G3"	995.562/0002	74	200	328	45	398	3/8"	87	95	29 Kg
	Q Flange	G3"	995.562/0003	74	200	318	83	388	3/8"	87	-	29 Kg

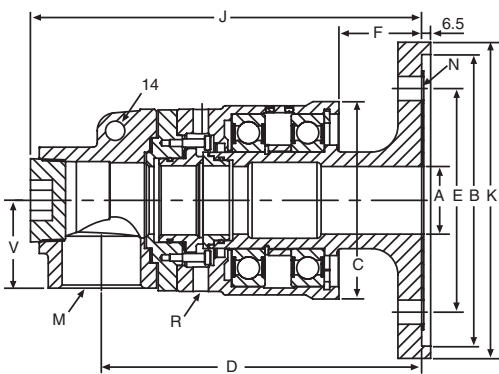

2" and 2 1/2" flanged rotor

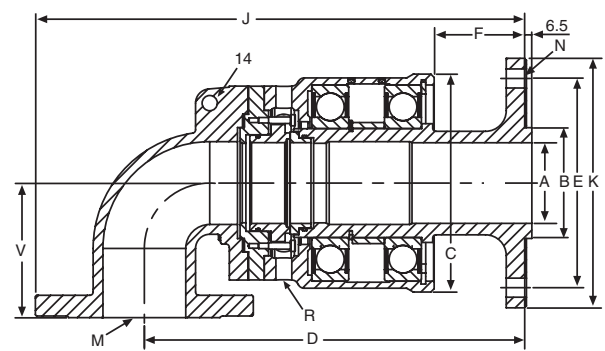

3" integral flange

Model	K Rotor Flange	M** RH	Part ID Water*	A	B	C	D	E	F	J	N	R NPT 8 x RH	V	Approx. Weight
4200	229	G2"	995.550/0017	49	211,25	143	232	162	60	284	4 x 17,5	1/4"	64	18 Kg
	229	DN50PN16	995.607/	49	211,20	143	272	162	60	355	4 x 17,5	1/4"	94	19 Kg
4250	229	G2 1/2"	995.556/	61	211,25	174	265	162	66	328	4 x 17,5	1/4"	74	24 Kg
	229	DN65PN16	995.597/	61	211,20	174	305	162	66	398	6 x 17,5	1/4"	104	25 Kg
4300	229	G3"	995.562/	74	101,70	200	312	192	83	388	6 x 17,5	1/4"	87	33 Kg
	229	DN80PN16	995.563/	74	101,65	200	343	192	83	449	6 x 17,5	1/4"	124	34. Kg

\* For oil rotary joints and additional connection sizes/reducers, consult Kadant Johnson.  
 \*\* Thread is according to ISO-228-1.

Dimensions are in mm, are for reference only, and subject to change.

# Dual Flow



### Standard RX\* Ratings

Media:	Water/Air	Oil*
Pressure:	13 bar	10 bar
Temperature:	105°C	105°C
Speed:	1.000 RPM	1.000 RPM

\*Consult Kadant Johnson for abrasive fluids.

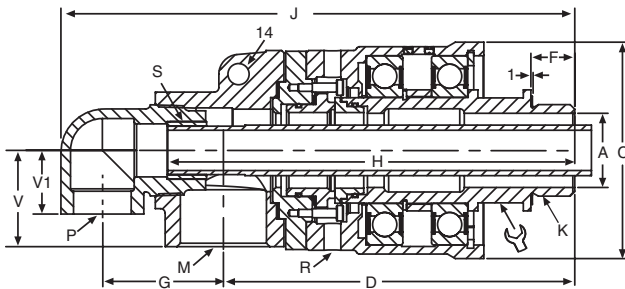

Straight thread rotor

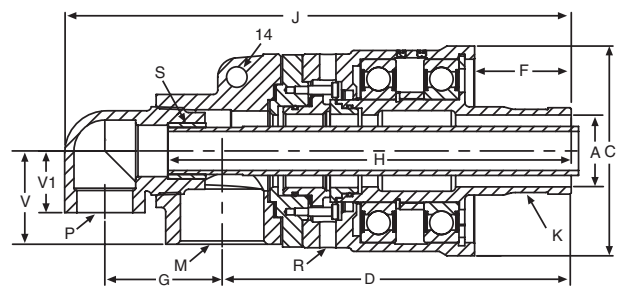

Q flange rotor

Model	K ISO-228-1 Rotor	M** RH	Part ID – Water*		A	C	D	F	G	H		J	P** RH	R NPT 8 x RH	S		V	V1	Approx. Weight	
			Dual Flow Fixed Pipe	Dual Flow Rotary Pipe						Fixed Pipe	Rotary Pipe				Fixed Pipe ISO-228-1	Rotary Pipe OD f7				
4200	G2"-RH	G2"	995.553/0001	995.554/0001	49	143	232	29	80	263	269	340	G1"	1/4"	G1"-RH	32,2	64	42	70	14 Kg
	G2"-LH	G2"	995.553/0002	995.554/0002	49	143	232	29	80	263	269	340	G1"	1/4"	G1"-RH	32,2	64	42	70	14 Kg
	Q Flange	G2"	995.553/0003	995.554/0003	49	143	238	66	80	269	275	345	G1"	1/4"	G1"-RH	32,2	64	42	-	14 Kg
4250	G2 1/2"-RH	G2"	995.559/0001	995.560/0001	61	174	271	38	100	322	328	402	G1 1/2"	1/4"	G1 1/2"-RH	45	74	42	83	20 Kg
	G2 1/2"-LH	G2"	995.559/0002	995.560/0002	61	174	271	38	100	322	328	402	G1 1/2"	1/4"	G1 1/2"-RH	45	74	42	83	20 Kg
	Q Flange	G2"	995.559/0003	995.560/0003	61	174	271	72	100	322	328	402	G1 1/2"	1/4"	G1 1/2"-RH	45	74	42	-	20 Kg
4300	G3"-RH	G2"	995.567/0001	995.568/0001	74	200	388	45	126	388	407	491	G2"	3/8"	G2"-RH	60	87	61	95	32 Kg
	G3"-LH	G2"	995.567/0002	995.568/0002	74	200	388	45	126	388	407	491	G2"	3/8"	G2"-RH	60	87	61	95	32 Kg
	Q Flange	G2"	995.567/0003	995.568/0003	74	200	378	83	126	378	397	482	G2"	3/8"	G2"-RH	60	87	61	-	32 Kg

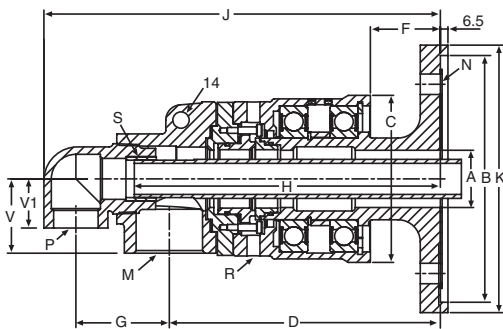

2" and 2 1/2" flanged rotor

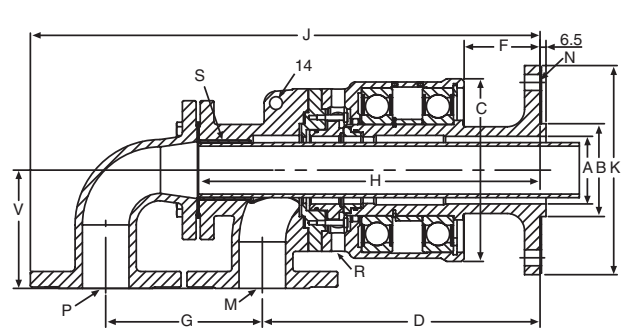

3" integral flange

Model	K Rotor Flange	M** RH	Part ID – Water*		A	B	C	D	F	G	H		J	N	P** RH	R NPT 8 x RH	S		V	V1	Approx. Weight
			Dual Flow Fixed Pipe	Dual Flow Rotary Pipe							Fixed Pipe	Rotary Pipe					Fixed Pipe ISO-228-1	Rotary Pipe OD f7			
4200	229	G2"	995.553/	995.554/	49	211,25	143	233	60	80	263	262	340	4 x 17,5	G1"	1/4"	G1"-RH	32,2	64	42	18 Kg
	229	DN25PN16	995.609/	995.611/	49	211,20	143	223	60	122	259	273	402	4 x 17,5	DN25PN16	1/4"	G1"-RH	32,2	101	101	20 Kg
4250	229	G2 1/2"	995.559/	995.560/	61	211,25	174	265	66	100	315	321	396	4 x 17,5	G1 1/2"	1/4"	G1 1/2"-RH	45	74	41	26 Kg
	229	DN40PN16	995.618/	995.621/	61	211,20	174	256	66	157	293	314	488	6 x 17,5	DN40PN16	1/4"	G1 1/2"-RH	45	117	117	31 Kg
4300	229	G3"	995.567/	995.568/	74	101,70	200	318	83	126	378	397	481	6 x 17,5	G2"	3/8"	G2"-RH	60	87	61	36 Kg
	229	DN50PN16	995.625/	995.570/0001	74	101,65	200	304	83	172	347	374	558	6 x 17,5	DN50PN16	3/8"	G2"-RH	60	130	130	43 Kg

\* For oil rotary joints and additional connection sizes/reducers, consult Kadant Johnson.  
 \*\* Thread is according to ISO-228-1.

Dimensions are in mm, are for reference only, and subject to change.  
 Siphon pipe supplied by the customer.

# 2" to 3"

## Single Flow



### Standard RX-1\* Ratings

Media:	Water/Air	Oil*
Pressure:	13 bar	10 bar
Temperature:	180°C	180°C
Speed:	1.000 RPM	1.000 RPM

\*Consult Kadant Johnson for abrasive fluids and RX-2 unions for applications up to 205°C.

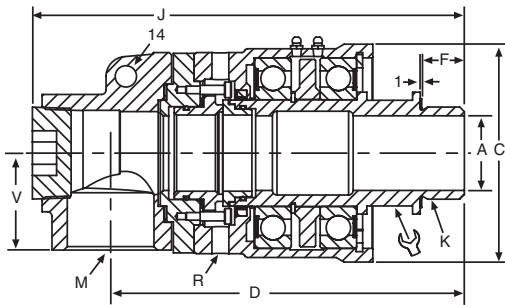

Straight thread rotor

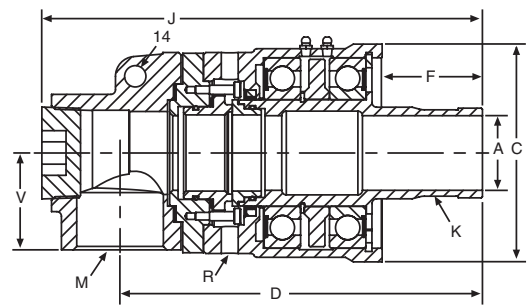

Q flange rotor

Model	K ISO-228-1 Rotor	M** RH	Part ID Water*	A	C	D	F	J	R NPT 8 x RH	V		Approx. Weight
4200	G2"-RH	G2"	995.416/0001	49	143	232	29	284	1/4"	64	70	13 Kg
	G2"-LH	G2"	995.416/0002	49	143	232	29	284	1/4"	64	70	13 Kg
	Q Flange	G2"	995.416/0003	49	143	232	66	289	1/4"	64	-	13 Kg
4250	G2 1/2"-RH	G2 1/2"	995.423/0001	61	174	271	38	334	1/4"	74	83	20 Kg
	G2 1/2"-LH	G2 1/2"	995.423/0002	61	174	271	38	334	1/4"	74	83	20 Kg
	Q Flange	G2 1/2"	995.423/0003	61	174	271	72	334	1/4"	74	-	20 Kg
4300	G3"-RH	G3"	995.429/0001	74	200	328	45	398	3/8"	87	95	29 Kg
	G3"-LH	G3"	995.429/0002	74	200	328	45	398	3/8"	87	95	29 Kg
	Q Flange	G3"	995.429/0003	74	200	318	83	388	3/8"	87	-	29 Kg

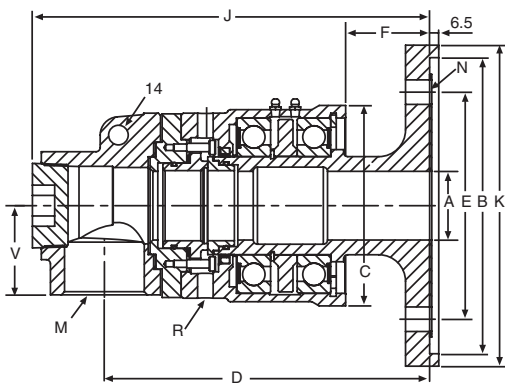

2" and 2 1/2" flanged rotor

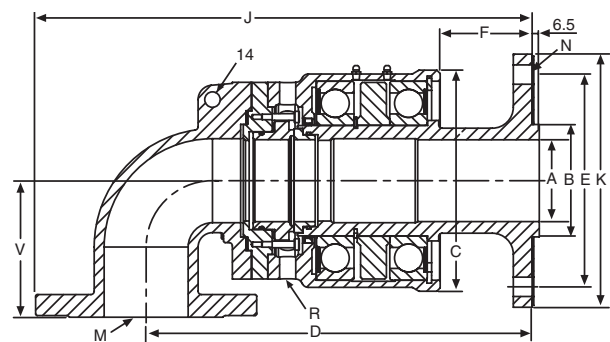

3" integral flange

Model	K Rotor Flange	M** RH	Part ID Water*	A	B	C	D	E	F	J	N	R NPT 8 x RH	V	Approx. Weight
4200	229	G2"	995.416/	49	211,3	143	232	162	60	284	4 x 17,5	1/4"	64	18 Kg
	229	DN50PN16	995.635/	49	211,2	143	272	162	60	355	4 x 17,5	1/4"	94	19 Kg
4250	229	G2 1/2"	995.423/	61	211,3	174	265	162	66	328	4 x 17,5	1/4"	74	24 Kg
	229	DN65PN16	995.689/	61	211,2	174	305	162	66	398	6 x 17,5	1/4"	104	25 Kg
4300	229	G3"	995.429/	74	101,7	200	312	192	83	388	6 x 17,5	1/4"	87	33 Kg
	229	DN80PN16	995.430/0001	74	101,7	200	343	192	83	449	6 x 17,5	1/4"	124	34 Kg

\* For oil rotary joints and additional connection sizes/reducers, consult Kadant Johnson.  
 \*\* Thread is according to ISO-228-1.

Dimensions are in mm, are for reference only, and subject to change.

# Dual Flow



### Standard RX-1\* Ratings

Media:	Water/Air	Oil*
Pressure:	13 bar	10 bar
Temperature:	180°C	180°C
Speed:	1.000 RPM	1.000 RPM

\*Consult Kadant Johnson for abrasive fluids and RX-2 unions for applications up to 205°C.

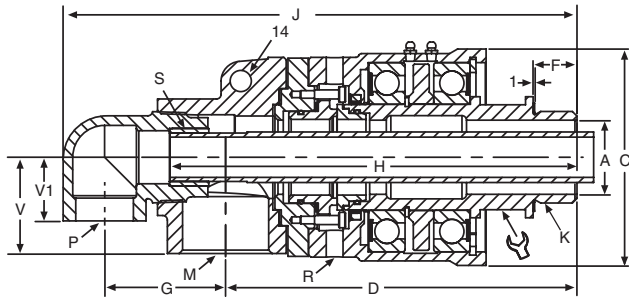

Straight thread rotor

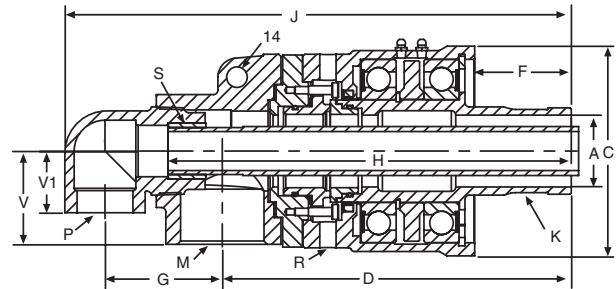

Q flange rotor

Model	K ISO-228-1 Rotor	M** RH	Part ID – Water*		A	C	D	F	G	H		J	P** RH	R NPT 8 x RH	S		V	V1	Approx. Weight	
			Dual Flow Fixed Pipe	Dual Flow Rotary Pipe						Fixed Pipe ISO-228-1	Rotary Pipe OD f7									
4200	G2"-RH	G2"	995.420/0001	995.421/0001	49	143	232	29	80	263	269	340	G1"	1/4"	G1"-RH	32,2	64	42	70	14 Kg
	G2"-LH	G2"	995.420/0002	995.421/0002	49	143	232	29	80	263	269	340	G1"	1/4"	G1"-RH	32,2	64	42	70	14 Kg
	Q Flange	G2"	995.420/0003	995.421/0003	49	143	238	66	80	269	275	345	G1"	1/4"	G1"-RH	32,2	64	42	-	14 Kg
4250	G2 1/2"-RH	G2"	995.426/0001	995.425/	61	174	271	38	100	322	328	402	G1 1/2"	1/4"	G1 1/2"-RH	45	74	42	83	20 Kg
	G2 1/2"-LH	G2"	995.426/0002	995.425/	61	174	271	38	100	322	328	402	G1 1/2"	1/4"	G1 1/2"-RH	45	74	42	83	20 Kg
	Q Flange	G2"	995.426/0003	995.425/	61	174	271	72	100	322	328	402	G1 1/2"	1/4"	G1 1/2"-RH	45	74	42	-	20 Kg
4300	G3"-RH	G2"	995.434/0001	995.435/0001	74	200	388	45	126	388	407	491	G2"	3/8"	G2"-RH	60	87	61	95	32 Kg
	G3"-LH	G2"	995.434/0002	995.435/0002	74	200	388	45	126	388	407	491	G2"	3/8"	G2"-RH	60	87	61	95	32 Kg
	Q Flange	G2"	995.434/0003	995.435/0003	74	200	378	83	126	378	397	482	G2"	3/8"	G2"-RH	60	87	61	-	32 Kg

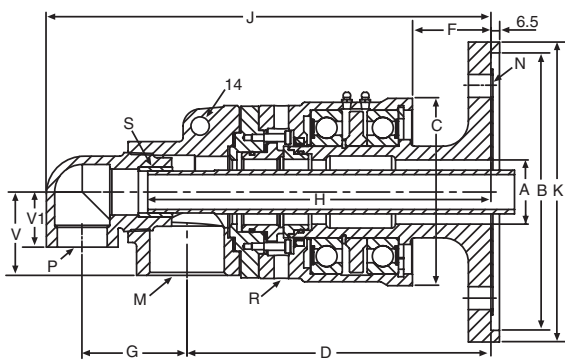

2" and 2 1/2" flanged rotor

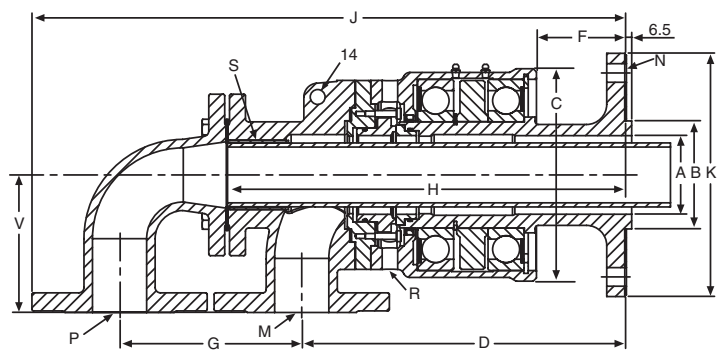

3" integral flange

Model	K Rotor Flange	M** RH	Part ID – Water*		A	B	C	D	F	G	H		J	N	P** RH	R NPT 8 x RH	S		V	V1	Approx. Weight
			Dual Flow Fixed Pipe	Dual Flow Rotary Pipe							Fixed Pipe ISO-228-1	Rotary Pipe OD f7									
4200	229	G2"	995.421/s	995.421/s	49	211,3	143	233	60	80	263	262	340	4 x 17,5	G1"	1/4"	G1"-RH	32,2	64	42	18 Kg
	229	DN25PN16	995.637/	995.639/	49	211,2	143	223	60	122	259	273	402	4 x 17,5	DN25PN16	1/4"	G1"-RH	32,2	101	101	20 Kg
4250	229	G2 1/2"	995.426/	995.425/	61	211,3	174	265	66	100	315	321	396	4 x 17,5	G1 1/2"	1/4"	G1 1/2"-RH	45	74	41	26 Kg
	229	DN40PN16	995.689/	995.645/	61	211,2	174	256	66	157	293	314	488	6 x 17,5	DN40PN16	1/4"	G1 1/2"-RH	45	117	117	31 Kg
4300	229	G3"	995.434/	995.435/	74	101,7	200	318	83	126	378	397	481	6 x 17,5	G2"	3/8"	G2"-RH	60	87	61	36 Kg
	229	DN50PN16	995.652/	995.572/	74	101,7	200	304	83	172	347	374	558	6 x 17,5	DN50PN16	3/8"	G2"-RH	60	130	130	43 Kg

\* For oil rotary joints and additional connection sizes/reducers, consult Kadant Johnson.  
 \*\* Thread is according to ISO-228-1.

Dimensions are in mm, are for reference only, and subject to change.  
 Syphon pipe supplied by the customer.

# 2" to 3"

## Single Flow



### Standard RX-3\* Ratings

Media:	Oil
Pressure:	10 bar
Temperature:	250°C
Speed:	1.000 RPM

\*Consult Kadant Johnson for abrasive fluids.

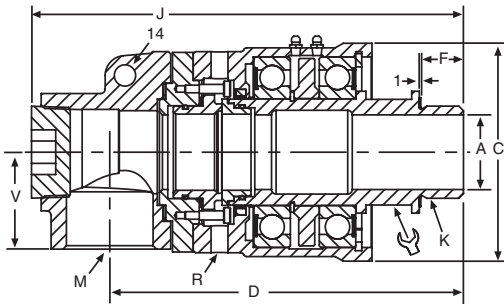

Straight thread rotor

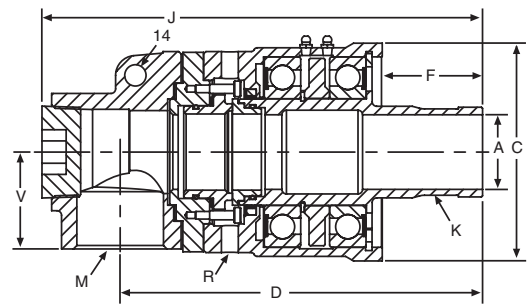

Q flange rotor

Model	K ISO-228-1 Rotor	M** RH	Part ID Oil	A	C	D	F	J	R NPT 8 x RH	V		Approx. Weight
4200	G2"-RH	G2"	995.709/	49	143	232	29	284	1/4"	64	70	13 Kg
	G2"-LH	G2"	995.709/	49	143	232	29	284	1/4"	64	70	13 Kg
	Q Flange	G2"	995.709/	49	143	232	66	289	1/4"	64	-	13 Kg
4250	G2 1/2"-RH	G2 1/2"	995.713/	61	174	271	38	334	1/4"	74	83	20 Kg
	G2 1/2"-LH	G2 1/2"	995.713/	61	174	271	38	334	1/4"	74	83	20 Kg
	Q Flange	G2 1/2"	995.713/	61	174	271	72	334	1/4"	74	-	20 Kg
4300	G3"-RH	G3"	995.716/	74	200	328	45	398	3/8"	87	95	29 Kg
	G3"-LH	G3"	995.716/	74	200	328	45	398	3/8"	87	95	29 Kg
	Q Flange	G3"	995.716/	74	200	318	83	388	3/8"	87	-	29 Kg

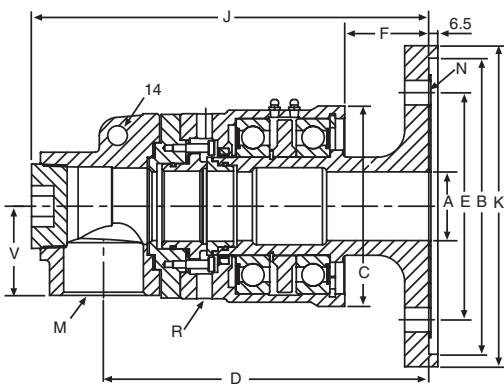

2" and 2 1/2" flanged rotor

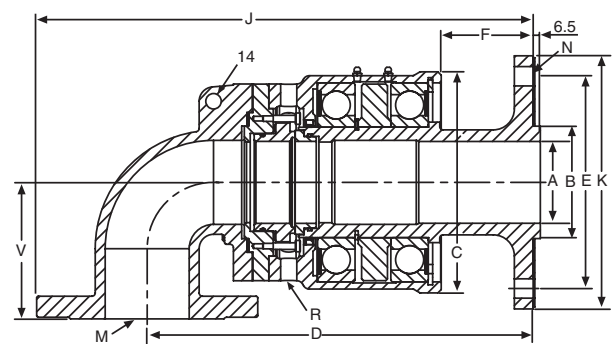

3" integral flange

Model	K Rotor Flange	M** RH	Part ID Oil	A	B	C	D	E	F	J	N	R NPT 8 x RH	V	Approx. Weight
4200	229	G2"	995.709/	49	211,3	143	232	162	60	284	4 x 17,5	1/4"	64	18 Kg
	229	DN50PN16	995.711/	49	211,2	143	272	162	60	355	4 x 17,5	1/4"	94	19 Kg
4250	229	G2 1/2"	995.713/	61	211,3	174	265	162	66	328	4 x 17,5	1/4"	74	24 Kg
	229	DN65PN16	995.714/	61	211,2	174	305	162	66	398	6 x 17,5	1/4"	104	25 Kg
4300	229	G3"	995.716/	74	101,7	200	312	192	83	388	6 x 17,5	1/4"	87	33 Kg
	229	DN80PN16	995.601/	74	101,7	200	343	192	83	449	6 x 17,5	1/4"	124	34 Kg

\* For additional connection sizes/reducers, consult Kadant Johnson.  
 \*\* Thread is according to ISO-228-1.

Dimensions are in mm, are for reference only, and subject to change.

# Dual Flow

# RX-3



### Standard RX-3\* Ratings

Media:	Oil
Pressure:	10 bar
Temperature:	250°C
Speed:	1.000 RPM

\*Consult Kadant Johnson for abrasive fluids

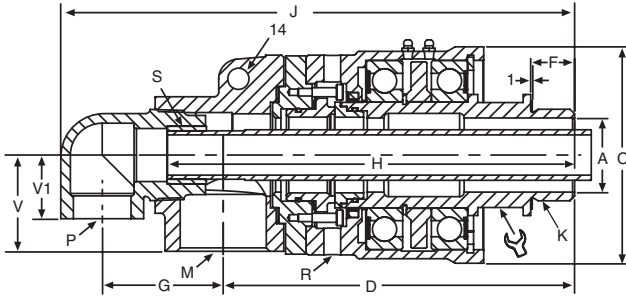

Straight thread rotor

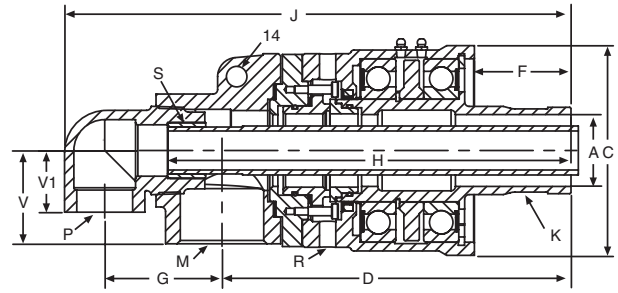

Q flange rotor

Model	K ISO-228-1 Rotor	M** RH	Part ID – Oil*		A	C	D	F	G	H		J	P** RH	R NPT 8 x RH	S		V	V1	Approx. Weight	
			Dual Flow Fixed Pipe	Dual Flow Rotary Pipe						Fixed Pipe ISO-228-1	Rotary Pipe OD f7									
4200	G2"-RH	G2"	995.405/	995.710/	49	143	232	29	80	263	269	340	G1"	1/4"	G1"-RH	32,2	64	42	70	14 Kg
	G2"-LH	G2"	995.405/	995.710/	49	143	232	29	80	263	269	340	G1"	1/4"	G1"-RH	32,2	64	42	70	14 Kg
	Q Flange	G2"	995.405/0001	995.710/	49	143	238	66	80	269	275	345	G1"	1/4"	G1"-RH	32,2	64	42	-	14 Kg
4250	G2 1/2"-RH	G2"	995.407/	995.453/	61	174	271	38	100	322	328	402	G1 1/2"	1/4"	G1 1/2"-RH	45	74	42	83	20 Kg
	G2 1/2"-LH	G2"	995.407/	995.453/	61	174	271	38	100	322	328	402	G1 1/2"	1/4"	G1 1/2"-RH	45	74	42	83	20 Kg
	Q Flange	G2"	995.407/	995.453/	61	174	271	72	100	322	328	402	G1 1/2"	1/4"	G1 1/2"-RH	45	74	42	-	20 Kg
4300	G3"-RH	G2"	995.409/	995.717/	74	200	388	45	126	388	407	491	G2"	3/8"	G2"-RH	60	87	61	95	32 Kg
	G3"-LH	G2"	995.409/	995.717/	74	200	388	45	126	388	407	491	G2"	3/8"	G2"-RH	60	87	61	95	32 Kg
	Q Flange	G2"	995.409/	995.717/	74	200	378	83	126	378	397	482	G2"	3/8"	G2"-RH	60	87	61	-	32 Kg

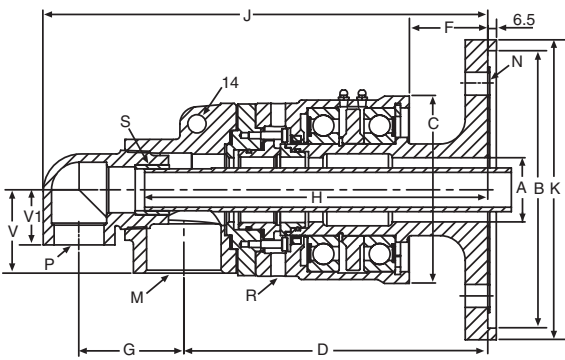

2" and 2 1/2" flanged rotor

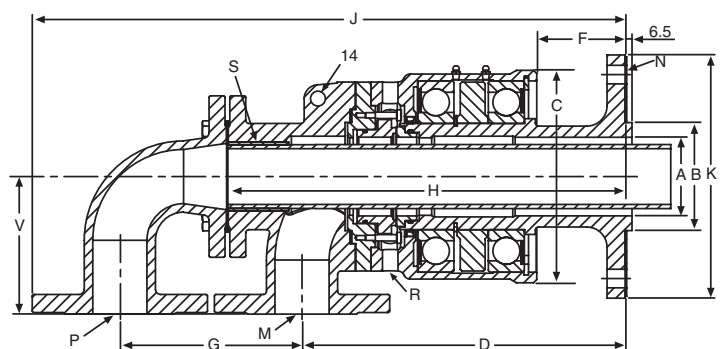

3" integral flange

Model	K Rotor Flange	M** RH	Part ID – Oil*		A	B	C	D	F	G	H		J	N	P** RH	R NPT 8 x RH	S		V	V1	Approx. Weight
			Dual Flow Fixed Pipe	Dual Flow Rotary Pipe							Fixed Pipe ISO-228-1	Rotary Pipe OD f7									
4200	229	G2"	995.405/	995.710/	49	211,3	143	233	60	80	263	262	340	4 x 17,5	G1"	1/4"	G1"-RH	32,2	64	42	18 Kg
	229	DN25PN16	995.712/	995.406/	49	211,2	143	223	60	122	259	273	402	4 x 17,5	DN25PN16	1/4"	G1"-RH	32,2	101	101	20 Kg
4250	229	G2 1/2"	995.407/	995.453/	61	211,3	174	265	66	100	315	321	396	4 x 17,5	G1 1/2"	1/4"	G1 1/2"-RH	45	74	41	26 Kg
	229	DN40PN16	995.715/	995.408/0001	61	211,2	174	256	66	157	293	314	488	6 x 17,5	DN40PN16	1/4"	G1 1/2"-RH	45	117	117	31 Kg
4300	229	G3"	995.409/	995.717/	74	101,7	200	318	83	126	378	397	481	6 x 17,5	G2"	3/8"	G2"-RH	60	87	61	36 Kg
	229	DN50PN16	995.718/	995.410/0001	74	101,7	200	304	83	172	347	374	558	6 x 17,5	DN50PN16	3/8"	G2"-RH	60	130	130	43 Kg

\* For additional connection sizes/reducers, consult Kadant Johnson.  
\*\* Thread is according to ISO-228-1.

Dimensions are in mm, are for reference only, and subject to change.  
Syphon pipe supplied by the customer.

# 4" RX

## Single and Dual Flow



### Standard RX\* Ratings

Media:	Water	Oil
Pressure:	10 bar	10 bar
Temperature:	145°C	145°C
Speed:	750 RPM	750 RPM

\*Consult Kadant Johnson for abrasive fluids.

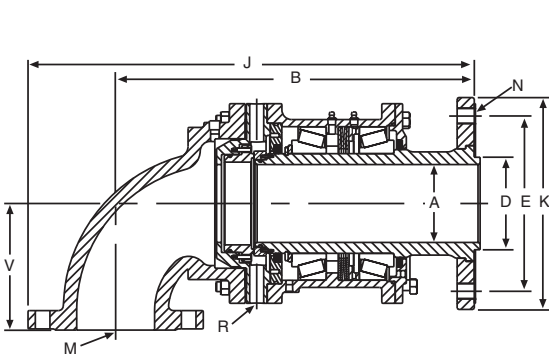

Single flow flanged connection

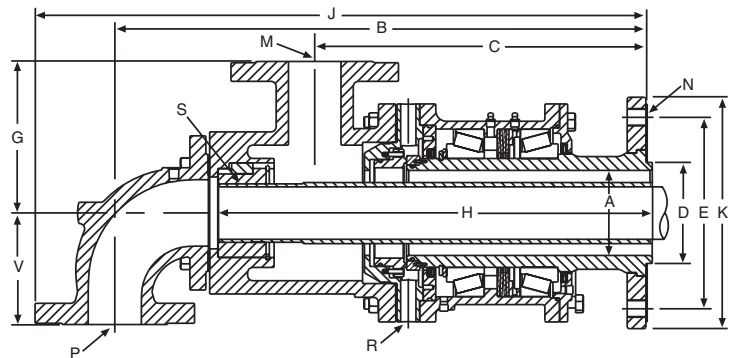

Dual flow flanged connection

Model	K Rotor	M ISO-228-1 RH	Part ID Water*	A	B	C	D*	E	G	H	J	N	P	R BSPT 4 x RH	S	V	Approx. Weight
4400 Single	276	DN100 PN16	995.571/0001	102	415	-	120,60 120,55	228,6	-	-	530	6 x 21,5 8 x 21,5	-	1/2"	-	165	75 Kg
4400 Dual Stationary	276	DN65 PN16	995.413/0001	102	582	343	120,60 120,55	228,6	181	466	677	6 x 21,5 8 x 21,5	DN65 PN16	1/2"	G2 1/2	133	95 Kg
4400 Dual Rotating	276	DN65 PN16	995.574/0001	102	582	343	120,60 120,55	228,6	181	466	677	6 x 21,5 8 x 21,5	DN65 PN16	1/2"	75	133	95 Kg

\* For oil and additional connection sizes/reducers, consult Kadant Johnson.  
\* Pilot length 7,6 mm.

Dimensions are in mm, are for reference only, and subject to change.  
Syphon pipe supplied by the customer.

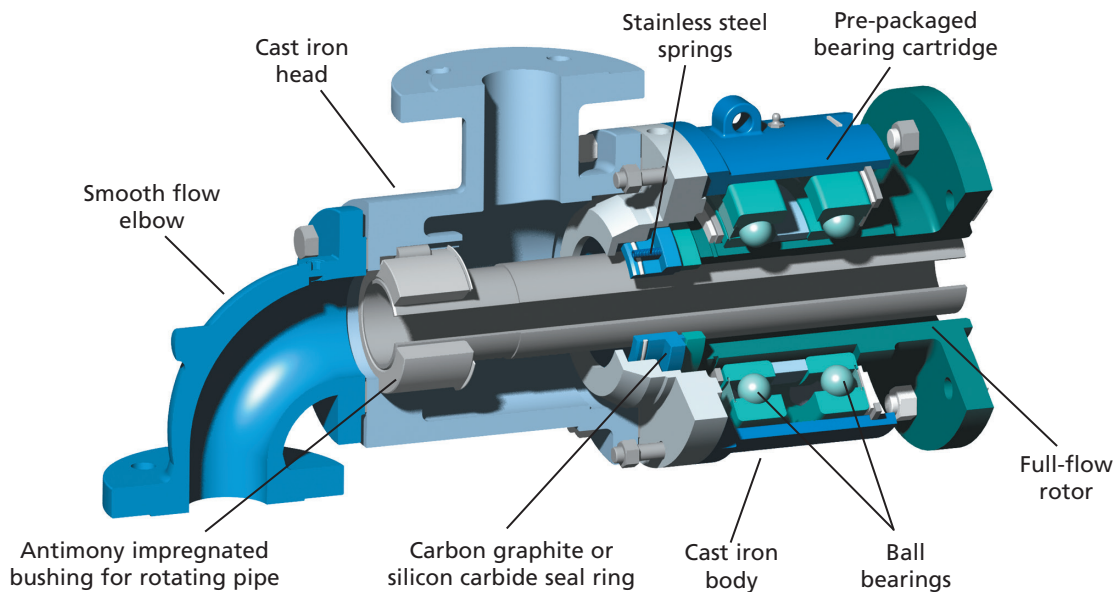



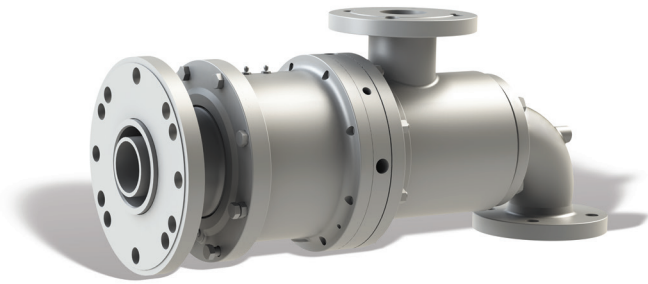

**Standard RX-1, -2, -3\* Ratings**

Media:	Water/Steam	Oil -1, -2, -3
Pressure:	10 bar/8 bar	10 bar
Temperature:	160°C	160°, 205°, 250°C
Speed:	750 RPM	750 RPM

\*Consult Kadant Johnson for abrasive fluids.

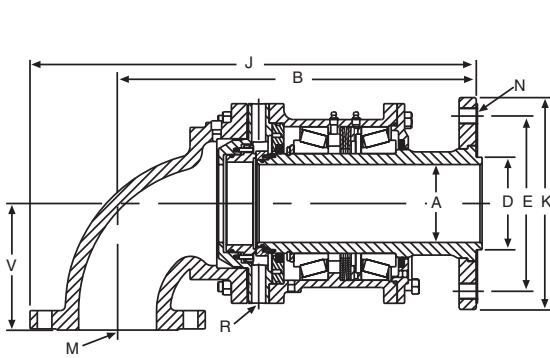

Single flow flanged connection

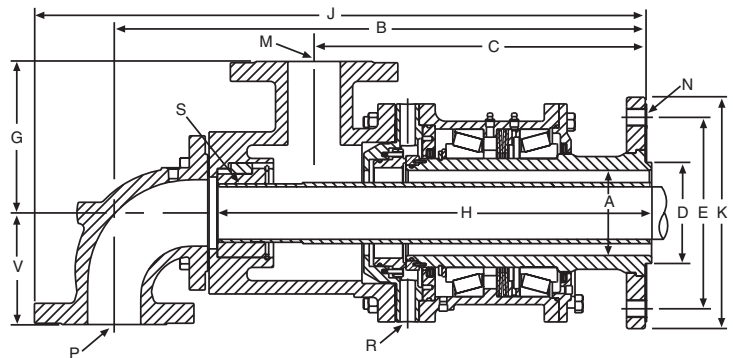

Dual flow flanged connection

Model	K Rotor	M ISO-228-1 RH	Part ID RX-1 Water*	Part ID RX-2 Oil*	Part ID RX-3 Oil*	A	B	C	D*	E	G	H	J	N	P	R BSPT 4 x RH	S	V	Approx. Weight
4400 Single	276	DN100 PN16	995.438/0001	995.679/	995.719/0001	102	469	-	120,60 120,55	228,60	-	-	584	6 x 21,5 8 x 21,5	-	1/2"	-	165	75 Kg
4400 Dual Stationary	276	DN65 PN16	995.723/	995.680/	995.720/	102	636	397	120,60 120,55	228,60	181	513	730	6 x 21,5 8 x 21,5	DN65 PN16	1/2"	G2 1/2	133	95 Kg
4400 Dual Rotating	276	DN65 PN16	995.441/0001	995.681/0001	995.414/0002	102	636	397	120,60 120,55	228,60	181	513	730	6 x 21,5 8 x 21,5	DN65 PN16	1/2"	75	133	95 Kg

\* For additional connection sizes, contact Kadant Johnson. Pilot length 7,6 mm.

Dimensions are in mm, are for reference only, and subject to change. Syphon pipe supplied by the customer.

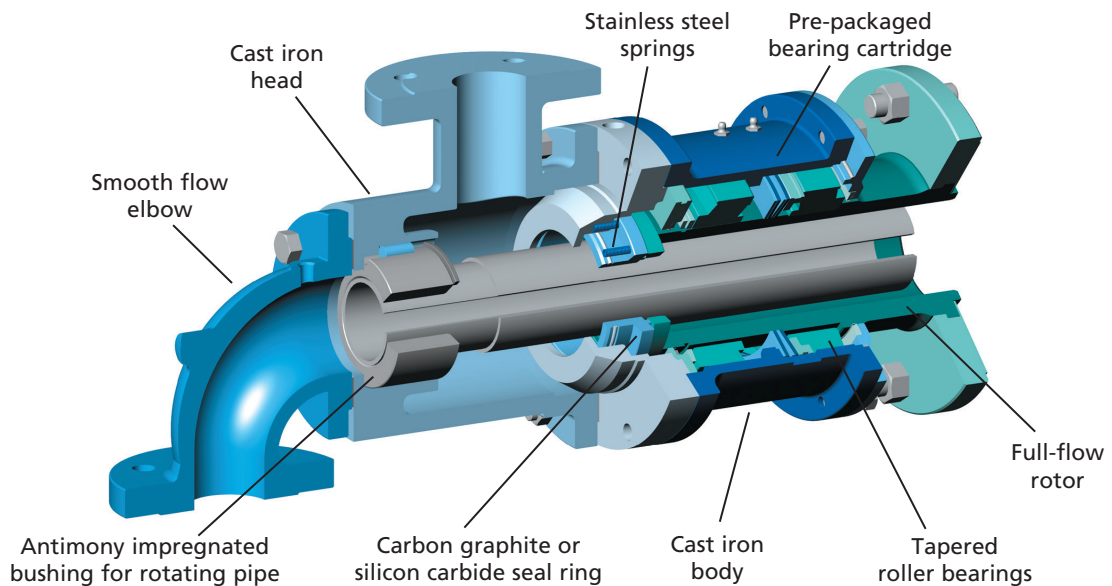

# 5" to 6" RX-1, RX-2, RX-3

Single and Dual Flow



### Standard RX-1, -2, -3 Ratings

Media:	Water/Steam	Oil -1, -2, -3
Pressure:	13 bar/8 bar	10 bar
Temperature:	160°C	160°, 205°, 250°C
Speed:	750 RPM	750 RPM

\*Consult Kadant Johnson for unknown part ID's.

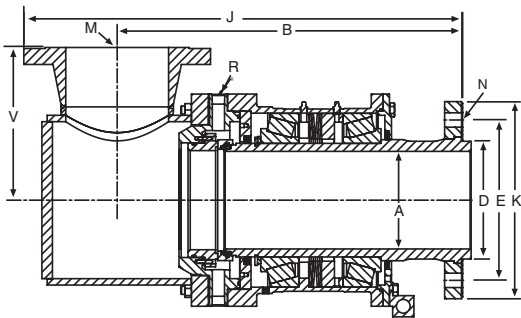

Single flow flanged connection

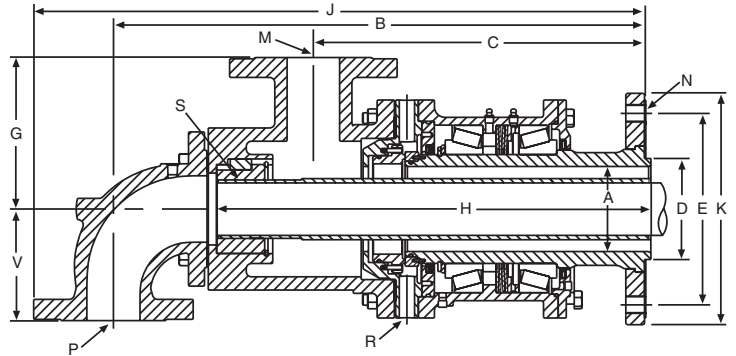

Dual flow flanged connection

Model	K Rotor	M ISO-228-1	Part ID RX-1 Water*	Part ID RX-2 Oil*	Part ID RX-3 Oil*	A	B	C	D*	E	G	H	J	N	P	R BSPT 4 x RH	S	V	Approx. Weight
4500 Single	279	DN125 PN16	995.444/	995.682/	995.721/	127	486	-	159,89 159,79	225	-	-	610	6 x 21,5 8 x 21,5	-	1/2"	-	194	120 Kg
4500 Dual**	279	DN80 PN16	995.445/	995.684/	995.415/0001	127	662	428	159,89 159,79	225	212	507	786	6 x 21,5 8 x 21,5	DN80 PN16	1/2"	85	140	127 Kg
4600 Single	295	DN150 PN16	995.733/	995.730/	995.729/	146	498	-	176,2	240	-	-	657	8 x 21,5	-	1/2"	-	227	- Kg
4600 Dual**	295	DN100 PN16	995.726/0001	995.732/	995.727/	146	751	498	176,2	240	229	581	860	8 x 21,5	DN100 PN16	1/2"	110	156	- Kg

\* For additional connection sizes, contact Kadant Johnson.

\*\* Rotary syphon, for static syphon, consult Kadant Johnson.

Pilot length 5" 7,6 mm Pilot length 6" 14,2 mm

Syphon pipe supplied by the customer.

Dimensions are in mm, are for reference only, and subject to change.

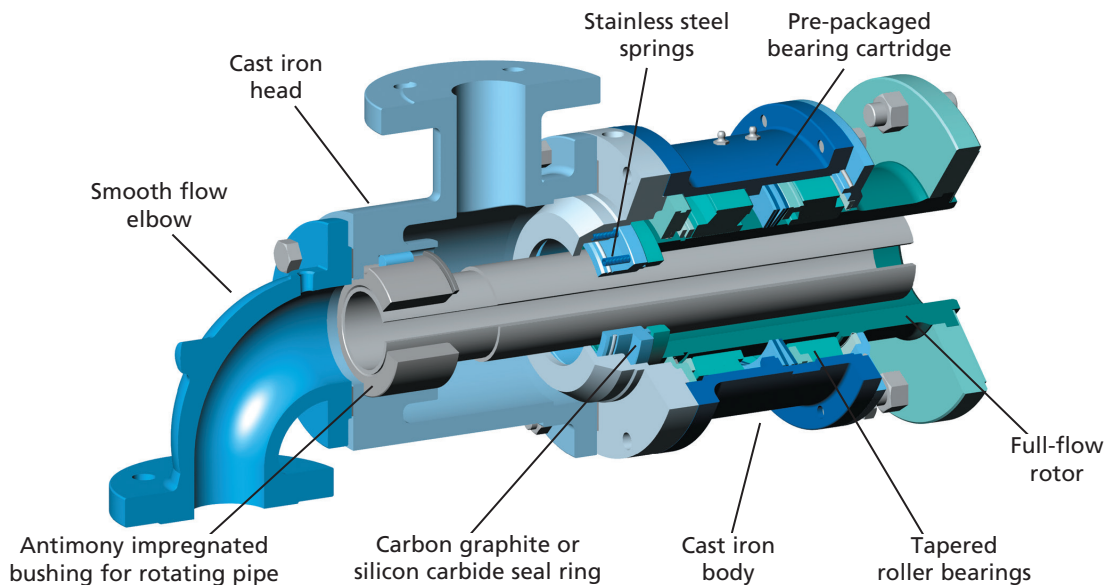

# Engineering Data

## Rotary Union Sizing

Rotary unions that are used for liquid flow are typically sized so that the pressure drop is less than 0,20 bar for open-loop systems and less than 0,40 bar for closed-loop systems. The pressure drop through a dual flow rotary union is higher than the pressure drop through a single flow union of the same size, because the internal flow area is lower. Use the appropriate chart below for your configuration. Note that the pressure drop shown for dual flow unions is for the supply passage. The total pressure drop (flow in and flow out) would be approximately 2x this value.

RX Rotary Union (Single Flow)

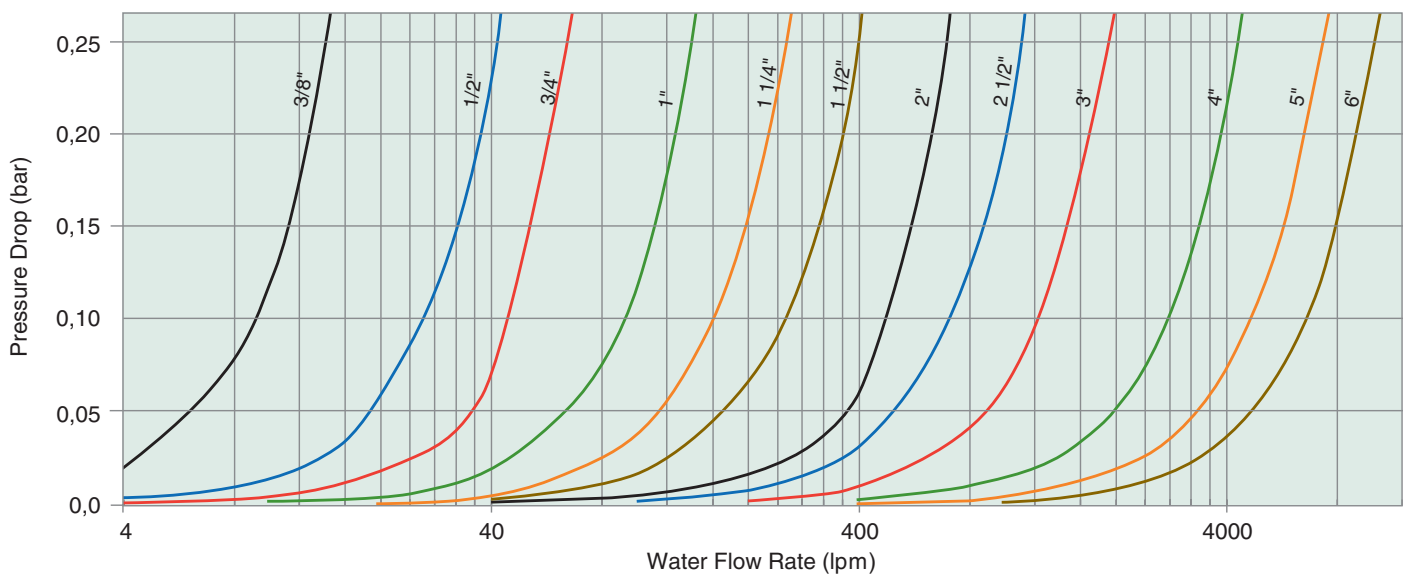

RX Rotary Union (Dual Flow)

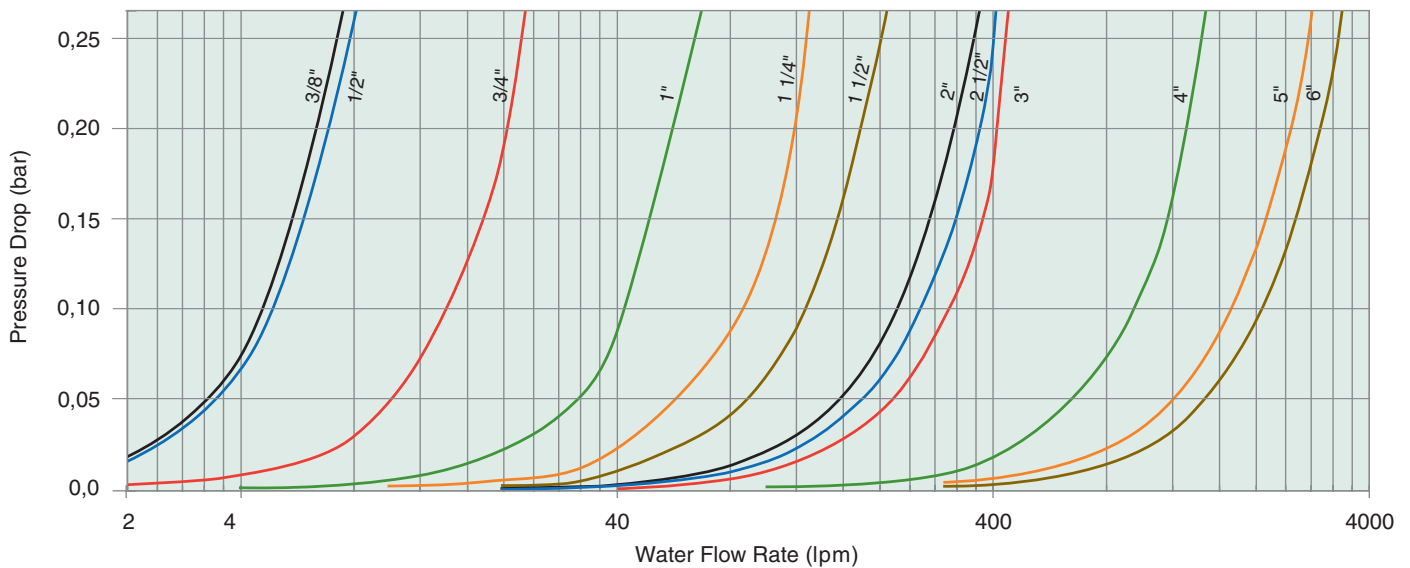

---

# Custom Solutions

---



### Special RX, connectivity flexibility

This RX line developed on special demands for plastic film customers. Special fixed rotor connections and SAE flange provisions for thermal oil applications make these joints versatile for a large variety of applications. This version is designed as 1½", and is rated up to 105°C, 10 bar and 1.500 RPM.

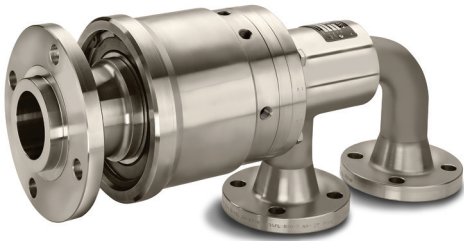

### Special RX, complying flexibility

RX unions for applications in the pharmaceutical, food, and petrochemical industries that need to comply with e.g. CIP, ATEX or FDA certification can be delivered to custom specification. This RX union is suitable for a large range of temperatures for which we can supply special elastomers for optimal performance and durability. Temperatures far below freezing point are also possible.



### Special RX, industry application flexibility

This RX was initially designed for the food industry and is a complete stainless steel rotary union with a bronze nipple. It is applied in a slow speed cooling application in manufacturing. This RX is available in 1½" and 2" and is rated up to 105°C, 13 bar and 1.000 RPM.

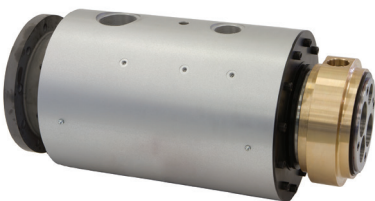

### Special multi-passage flexibility

This multi-passage union was developed for index machines applications. A combination of Duraseal™ technologies and mechanical seals are used to guarantee a long life and high up-time. Various media possible like air, vacuum, methane, and water. Rotary unions can be designed to integrate perfectly with the requirements of customized machines.

# Cartridge Options

## Repair Kits

Model	Cartridge	Part ID	Seal	Counterseat	Secondary Seal*	Grease*	Temp. °C	Pressure (Bar)		
								Water	Oil	Steam
4038/4050	RX	860.350	Carbon Graphite	Tungsten Carbide	Aflas	Commercial	105	13	10	N.R.
	RX-1		Aflas		Krytox	180	8			
	RX-2	860.352	Silicon Carbide		Aflas	Krytox	205			N/A
	RX-3	860.353			Kalrez	Krytox	230			N/A
4075	RX	860.355	Carbon Graphite	Tungsten Carbide	Aflas	Commercial	105	13	10	N.R.
	RX-1		Aflas		Krytox	180	8			
	RX-2	860.357	Silicon Carbide		Aflas	Krytox	205			N/A
	RX-3	860.358			Kalrez	Krytox	230			N/A
4100	RX	860.360	Carbon Graphite	Tungsten Carbide	Aflas	Commercial	105	13	10	N.R.
	RX-1		Aflas		Krytox	180	8			
	RX-2	860.362	Silicon Carbide		Aflas	Krytox	205			N/A
	RX-3	860.363			Kalrez	Krytox	230			N/A
4125	RX	860.365	Carbon Graphite	Tungsten Carbide	Aflas	Commercial	105	13	10	N.R.
	RX-1		Aflas		Krytox	180	8			
	RX-2	860.367	Silicon Carbide		Aflas	Krytox	205			N/A
	RX-3	860.368			Kalrez	Krytox	230			N/A
4150	RX	860.370	Carbon Graphite	Tungsten Carbide	Aflas	Commercial	105	13	10	N.R.
	RX-1		Aflas		Krytox	180	8			
	RX-2	860.372	Silicon Carbide		Aflas	Krytox	205			N/A
	RX-3	860.373			Kalrez	Krytox	230			N/A
4200	RX	860.320	Carbon Graphite	Tungsten Carbide	Aflas	Commercial	105	13	10	N.R.
	RX-1	860.300			Aflas	Krytox	180			8
	RX-2	860.302	Silicon Carbide		Aflas	Krytox	205			N/A
	RX-3	860.307			Kalrez	Krytox	250			N/A
4250	RX	860.308	Carbon Graphite	Tungsten Carbide	Aflas	Commercial	105	13	10	N.R.
	RX-1	860.321			Aflas	Krytox	180			8
	RX-2	860.309	Silicon Carbide		Aflas	Krytox	205			N/A
	RX-3	860.310			Kalrez	Krytox	250			N/A
4300	RX	860.322	Carbon Graphite	Tungsten Carbide	Aflas	Commercial	105	13	10	N.R.
	RX-1	860.311			Aflas	Krytox	180			8
	RX-2	860.312	Silicon Carbide		Aflas	Krytox	205			N/A
	RX-3	860.313			Kalrez	Krytox	250			N/A
4400	RX	860.303	Carbon Graphite	Tungsten Carbide	Aflas	Commercial	145	10	10	N.R.
	RX-1		Aflas		Krytox	160	8			
	RX-2	860.314	Silicon Carbide		Aflas	Krytox	205			N/A
	RX-3	860.304			Kalrez	Krytox	250			N/A
4500	RX-1	860.315	Carbon Graphite	Tungsten Carbide	Aflas	Krytox	160	10	10	8
	RX-2	860.316	Silicon Carbide		Aflas	Krytox	205			N/A
	RX-3	860.306			Kalrez	Krytox	250			N/A
4600	RX-1	860.317	Carbon Graphite	Tungsten Carbide	Aflas	Krytox	160	10	10	8
	RX-2	860.318	Silicon Carbide		Aflas	Krytox	205			N/A
	RX-3	860.319			Kalrez	Krytox	250			N/A

N.R. = not recommended

N/A = not applicable

\*Aflas, Kalrez, and Krytox are registered trademarks owned by their respective companies.

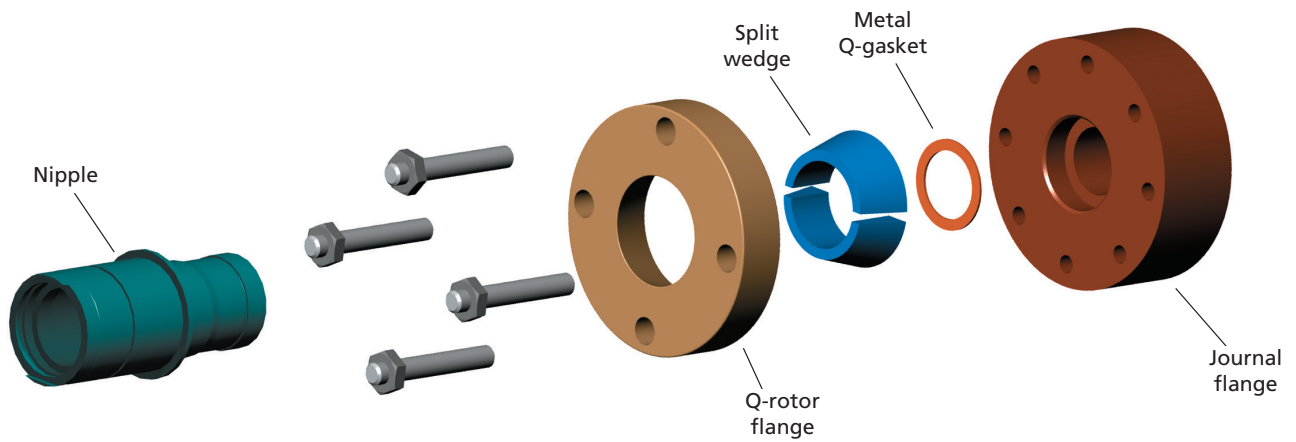

# Quick Release Flange



Model	Rotary Joint Size	Flange (n)	Flange Set (Water/Air/Steam)	Flange Set (Oil)	Flange	Split Wedge	Gasket Copper Water/Air/Steam	Gasket Aluminium Oil
4100	1"	4 holes	050.303	050.403	050.003	550.003	080.053	080.102
4125	1 1/4"	4 holes	050.304	050.404	050.004	550.004	080.054	080.103
4150	1 1/2"	4 holes	050.305	050.405	050.005	050.005	080.055	080.104
4200	2"	4 holes	050.306	050.406	050.006	050.006	080.056	080.105
4250	2 1/2"	4 holes	050.307	050.407	050.007	050.007	080.057	080.106
4300	3"	4 holes	050.317	050.417	050.011	050.008	080.058	080.107
		5 holes	050.308	050.408	050.008			
		6 holes	050.318	050.418	050.012			

Flange set includes: Q-flange, split wedges, and metal Q-gasket.

Quick Release Flanges are used for increased ease of installation and reduced maintenance cost. The Quick Release Flange can be used for steam, water, oil, and all other media which passes through the rotary joint.

 <h2>Features</h2> <ul style="list-style-type: none"> <li>• Split wedge construction for ease of installation</li> <li>• Q-Flange can be used for LH and RH rotation</li> <li>• Gaskets for different media</li> <li>• Mounting with multiple bolts</li> <li>• Sizes available from 1/2" up to 3"</li> </ul>	 <h2>Benefits</h2> <ul style="list-style-type: none"> <li>• Reduced installation and maintenance time</li> <li>• Simplified inventory</li> <li>• Application for all media</li> <li>• Easy installation with hand tools</li> </ul>
---	---

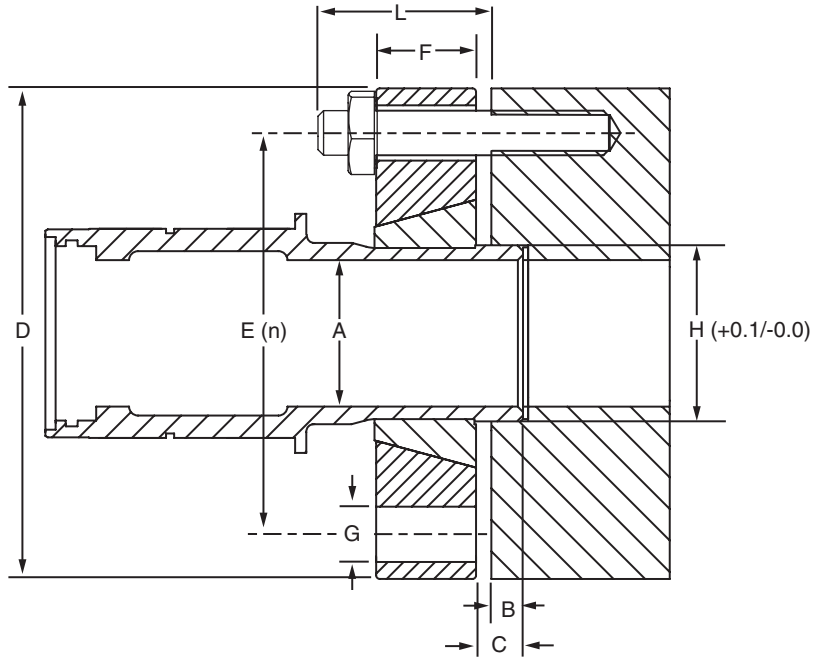

Model	Rotary Joint Size	A	B	C	D	E	F	G	H	L	n	Torque (Nm) Copper Gasket	Torque (Nm) Aluminium Gasket	Kg
4100	1"	24,5	8	11,1	127	88,9	15	14,25	32,5	M12x35	4	21	19	1,3
4125	1 1/4"	32,5	10	12,7	127	88,9	16	14,25	41,3	M12x35	4	23	21	1,3
4150	1 1/2"	38	10	12,7	140	100	20	14,25	47,6	M12x40	4	25	22	1,9
4200	2"	48	13	15,9	165	120,6	20	14,25	59,1	M12x40	4	29	25	2,6
4250	2 1/2"	59	16	19	165	120,6	20	14,25	72,2	M12x40	4	34	28	2,5
4300	3"	73	19	22,2	203	171,5	31	17,5	87,3	M16x55	4	72	62	5,9
											5	66	57	
											6	61	54	

Dimensions are in mm, are for reference only, and subject to change.

### Ordering Information

If you have an existing Kadant Johnson rotary union with a product label affixed to the housing, the Part ID written on the label is all that is required to order a replacement union. For new applications or if no Part ID is available, the following data are requested:

1. Number of passages (single flow or dual flow)
2. Rotor type (threaded, Q-flange, or integral flange)
3. Rotor thread (right- or left-hand and type)
4. Supply pipe (none, fixed, or rotating)
5. Service (water, thermal oil, air, or steam)
6. Fluid pressure
7. Fluid temperature
8. Rotational speed (rpm)
9. Connection sizes shown on drawing (M, P, S, K)

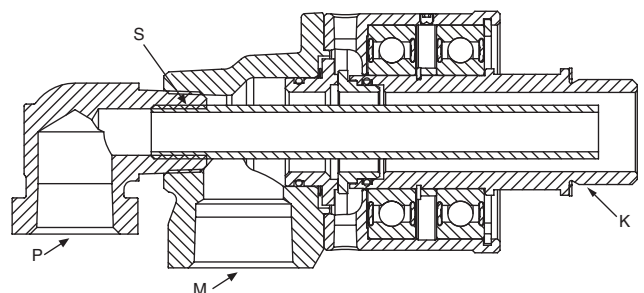
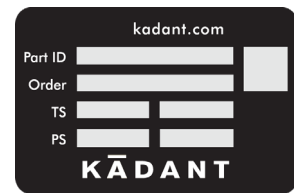

---

# Complementary Products

---

## Nozzles

A wide variety of nozzles are available for various industrial applications. These include both fan and needle jet nozzles constructed in stainless steel, brass, and other corrosion resistant materials with standard and custom fitting connections. Each nozzle is individually tested for pattern integrity.



---

## Roll Cleaning Blades

Roll cleaning blades are used in a variety of industries and applications including fiber processing, converting, corrugating, printing, roofing, steel, and food processing. Kadant offers more than 60 blade materials including UHMW poly, fiberglass, carbon, and metal. Blade thickness, bevel, and other features are customer-engineered for the specific application requirements.



---

## Roll Cleaning Blade Holders and Accessories

Roll cleaning blade holders feature quick and easy blade changing, precise adjustability, and flexible models that offer self-adjustability and uniform loading. Roll cleaning blade holders are available in steel, stainless steel, and lightweight composite materials.

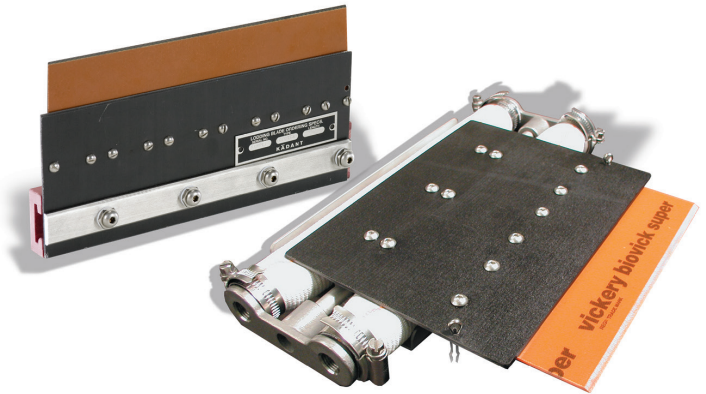

---

## Roll Cleaning Systems

Kadant roll cleaning systems provide a compact and unique technology that offers improved cleaning results for increased uptime and reduced maintenance costs in a variety of industrial roll and belt cleaning applications including drum flaking, fibre processing, filtration, and metal processing. Roll cleaning systems provide precise blade load adjustment and quick blade change.

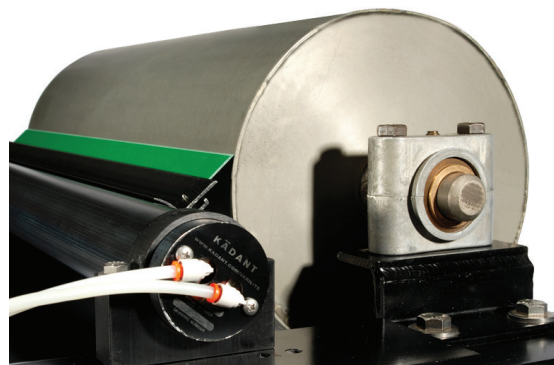



---

# Other Rotary Unions

---

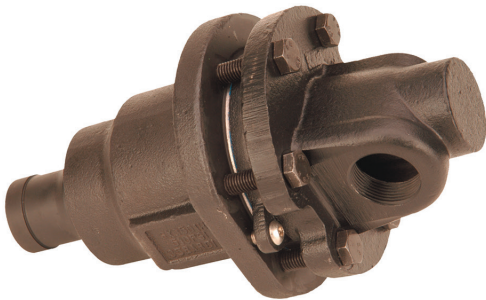

## **SX<sup>®</sup> Rotary Joint for Steam and Thermal Oil (¾" to 3")**

The SX rotary joint is designed for steam and thermal oil applications. Its two internal carbon-graphite bearings permit self-alignment and long operating life – even on cylinders that are not concentric. The convex seal ring and optimized seal diameter provide extended seal life and reduced maintenance for the SX rotary joint. The SX rotary joint line is available in sizes from ¾" to 3" and can be used in single or dual flow applications. The rotary joint is rated up to 343°C, 20 bar, and 550 RPM.

---



## **ELS<sup>™</sup> Rotary Joint for Steam and Thermal Oil (2" to 12")**

The ELS rotary joint is designed for use with steam and thermal oil service. The double-guide design provides internal support for the rotary joint and maintains alignment even when the roll or cylinder is not concentric. The ELS is available in sizes ranging from 2" to 12" and is rated up to 343°C, 50 bar, and 200 RPM.

---



## **G<sup>™</sup> Rotary Union for Coolant, Water, Air, and Hydraulic Oil**

The G rotary union is a high performance, high precision union for coolant, water, air, and hydraulic oil applications. G unions are generally applied to spindles, gun drills, milling, and other machinery. The G union is designed for smooth-running at speeds up to 50,000 RPM and pressures up to 400 bar in sizes ranging from ¼" to ⅝".

---



## **MP<sup>™</sup> Rotary Union for Pneumatic, Hydraulic, and Water Applications**

The MP rotary union is a custom-designed multi-passage union for pneumatic, hydraulic, and water applications. The precision ball bearings are lubricated for life and housing materials include stainless steel, aluminium, steel, or brass. Standard passage sizes are ⅛", ¼", ⅜", ½", ¾", and 1" with other sizes available. MP unions are available with up to 12 passages and rated up to 107°C, 207 bar, and 500 RPM.

# Recommendations

## Flexible Hose

To ensure free movement of the rotary union and elimination of side loading, the proper installation, type, and length of flexible hose should be used.

### Recommended Hose Length, Bend, and Offset (mm)

Pipe Size	Minimum Length (X)	Minimum Bend Radius	Maximum Offset
1/4"	200	140	50
3/8"	250	140	50
1/2"	250	150	38
3/4"	300	200	25
1"	375	225	38
1 1/4"	450	250	50
1 1/2"	450	300	50
2"	525	375	50
2 1/2"	550	355	60
3"	600	425	60
4"	700	550	75
5"	750	700	60
6"	850	850	60

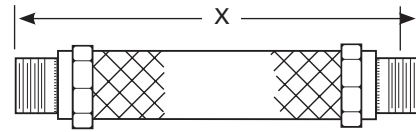

Threaded both ends

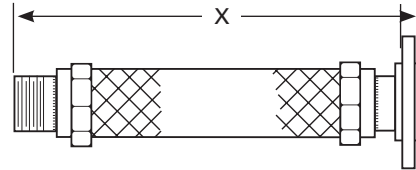

Threaded one end, lap flange other end

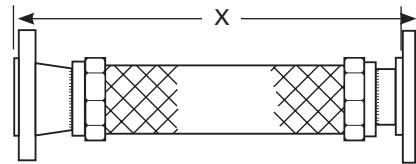

Fixed flange one end, lap flange other end

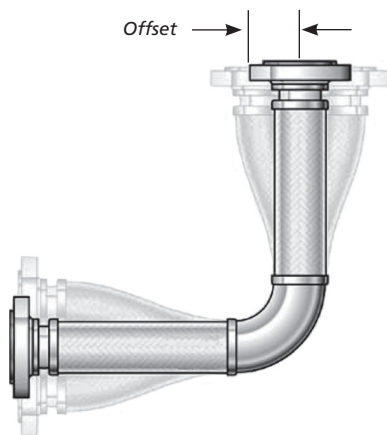

Compound hose  
(recommended)

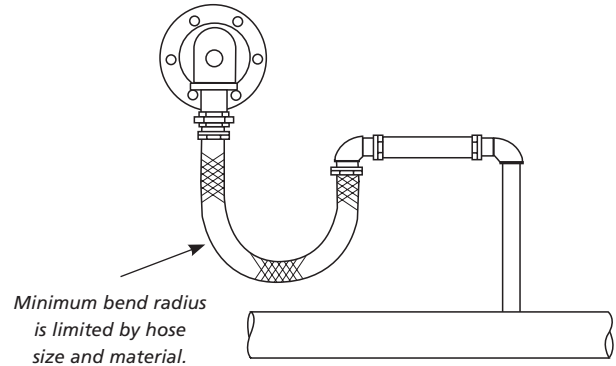

## Filtration

It is important to follow the filtration requirements recommended by the machinery manufacturer. RX rotary unions do not require additional filtration other than what is recommended for the fluid circulation system (typically 40–60 micron).

## Guarantee

RX rotary unions are tested and are warranted against manufacturing defects for 12 months. Kadant Johnson's global sales and service network stands behind its products and provides support to more than 150 countries worldwide.

### Threaded Supply Pipe

A threaded supply pipe is used for dual flow installations and is connected to the rotary union elbow using BSP threads. The size of the supply pipe determines the flow rate for a particular union size. The larger the pipe size, the higher the potential flow rate for a given size union. To avoid excessive stress at the pipe thread, the supply pipe length should not be longer than 4x the overall length of the rotary union.

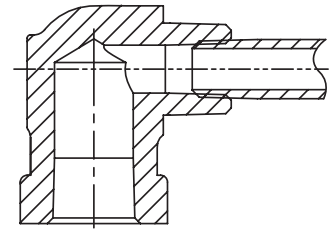

### Rotating Supply Pipe

A rotating supply pipe can be produced from tubing or iron pipe. The end of the pipe that is inserted into the rotary union elbow is machined to a specific tolerance to provide the proper fit and performance. It is recommended that the rotating supply pipe be supported inside the roll when attempting to use a supply pipe longer than 4x the length of the union. A straight thread rotor (for example, BSP or UNS) is used to ensure concentricity.

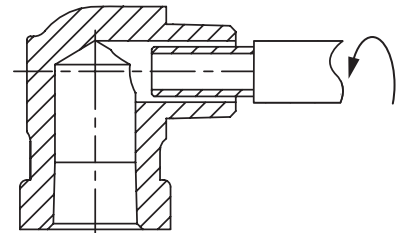

### Fixed Tube Supply Pipe

The fixed tube supply pipe is made of stainless steel tubing and is silver-soldered into the elbow of the rotary union. The lighter weight and thinner wall sections allow for higher flow rates and higher rotational speeds compared to alternative supply pipe designs. To avoid excessive stress at the tube-elbow interface, the supply pipe length should not be longer than 6x the overall length of the rotary union.

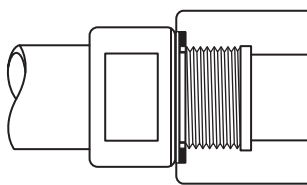
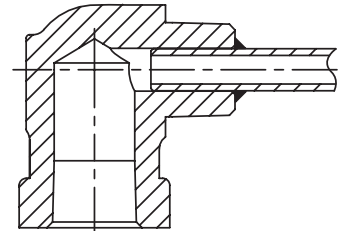

*Straight threads*

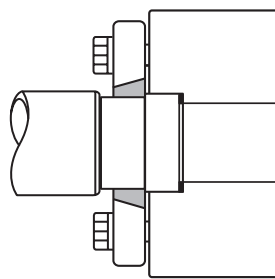

*Quick-release flange mounted to journal*

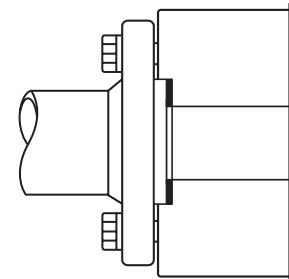

*Integral flange*

Size	Maximum Speed (RPM)		
	Straight Thread	Quick Release	Flanged
4038	3500	–	–
4050	3500	1000	–
4075	3500	1000	–
4100	3000	1000	3000
4125	2500	1000	2500
4150	2500	1000	2500
4200	750	1000	1000
4250	750	750	1000
4300	550	550	1000
4400	–	–	750
4500	–	–	750
4600	–	–	750



## GLOBAL SUPPORT

Many suppliers have made a commitment to the international market. But few have taken that commitment as far as Kadant. To ensure products are available where they are needed, Kadant's critical and high-value components are manufactured in North America, Europe, South America, and Asia.

Because expert advice and prompt service are as important as the products, Kadant has authorized representatives around the world. So wherever you are, Kadant products, service and support are close at hand.

### MANUFACTURING LOCATIONS



805 Wood Street  
Three Rivers, MI 49093 USA  
tel: +1 269 278 1715



Via Anhanguera, km 83,5 - CP 351/353  
13278-530, Valinhos, SP, Brazil  
tel: +55 19 3849 8700



Nijverheidslaan 23  
1382 LG Weesp, The Netherlands  
tel: +31 294 494200



Wuxi National Hi-Tech  
Industrial Development Zone  
Wuxi City, Jiangsu Province, China  
tel: +86 510 85212218

### SALES LOCATIONS

#### Germany

Langenfeld (Rheinland)  
Tel: +49 2173 97490  
sales.langenfeld@kadant.com

#### Spain

Sant Esteve de Sesrovires (Barcelona)  
Tel: +34 93 771 4410  
sales.spain@kadant.com

#### Poland

Poznan  
Tel: +48 601 702 639  
sales.poznan@kadant.com

#### France

Sartrouville (Paris)  
Tel: +33 1 61043010  
sales.paris@kadant.com

#### Italy

Pero, Milano  
Tel: +39 02 3394091  
info-jf@johnson-fluiten.com

#### Turkey

Istanbul  
Tel: +90 546 652 32 68  
sales.istanbul@kadant.com

#### Finland

Tampere  
Tel: +358 3 255 1111  
sales.tampere@kadant.com

#### Benelux

Weesp  
Tel: +31 294 494200  
sales.benelux@kadant.com

#### Czech Republic

Prague  
sales.prague@kadant.com

#### Sweden, Norway, Denmark

Huskvarna, Sweden  
Tel: +46 36 136080  
info.nordic@kadant.com

#### United Kingdom

Bury, Lancashire  
Tel: +44 61 764 9111  
sales.bury@kadant.com

#### India

Coimbatore  
Tel: +91 422 2442692  
sales.coimbatore@kadant.com